



# BEVERAGE-AIR

Project: _____	AIA#
Item: _____	
Location: _____	SIS#
Approved: _____	

**HR3HC TOP MOUNT REACH-IN REFRIGERATOR**

## HORIZON TOP MOUNT REACH-IN

### HR3HC Half-Solid Triple Door Reach-In Refrigerator

Hydrocarbon Series

**MODEL:**  
**HR3HC-1HS**



**7 Year Parts/Labor Warranty**  
**7 Year Compressor Warranty**

#### CABINET CONSTRUCTION

- Exterior is stainless steel front and continuous coil coated sides
- Interior liner is made of corrosion resistant aluminum
- Full electronic control
- One piece grille
- LED interior light
- Self-closing door with 120° stay-open feature, on cam-lift hinges
- Field reversible doors
- Door locks
- Snap-in magnetic gaskets for positive door seal
- Nine (9) heavy-duty epoxy coated wire shelves
- 6" Heavy-duty casters, two (2) with brakes
- 8' Cord and plug (see electrical data for details)

#### OPTIONS & ACCESSORIES

- Tray slide pair, 1 tray slide set for (1) 18" x 26" or (2) 14" x 18" pans (A)
- Stainless steel universal tray slide pair, 1 tray slide set for (1) 18" x 26" or (2) 14" x 18" pans (AC)
- Tray slide kit #4 (19 sets per half section)
- Additional shelves
- Shelf clips
- Stainless steel breaker
- 6" Legs seismic/flanged
- 3" Casters
- Remote option\* (see note on back page)

#### FINISH OPTIONS

- **HR Standard**  
(S/S front, continuous coil coated sides, aluminum interior)
- **HRP**  
(S/S front, S/S sides, aluminum interior)
- **HRS**  
(S/S front, continuous coil coated sides, S/S interior)
- **HRPS**  
(Complete S/S exterior & interior)

#### REFRIGERATION SYSTEM

- Uses environmentally friendly, energy efficient R290 refrigerant, and meets all regulatory requirements for CARB, SNAP, DOE & more
- Hot gas condensate evaporator
- Adaptive defrost
- Epoxy coated evaporator coil
- Maintains product temperatures between 36°F and 38°F



 Please verify qualifying units by visiting:  
[www.energystar.gov/cfs](http://www.energystar.gov/cfs)

3779 Champion Blvd., Winston-Salem, NC 27105  
1-888-845-9800 Fax: 1-336-245-6453  
Beverage-Air.com Sales@bevair.com



# BEVERAGE-AIR

MODEL	HR3HC-1HS
<b>EXTERNAL DIMENSIONAL DATA</b>	
Width Overall	78"
Depth Overall with Handles	33 5/8"
Height Overall	85"
Number of Doors	6
Depth with Door Open 90°	55 1/8"
Door Openings (in)	21 5/8" x 29 5/8"
<b>INTERNAL DIMENSIONAL DATA</b>	
NET Capacity (cubic ft.)	71.52
Internal Width Overall (in)	74"
Internal Depth Overall (in)	25 7/8"
Internal Height Overall (in)	62"
Number of Shelves	9
<b>ELECTRICAL DATA</b>	
Full Load Amperes **	6.0
Voltage	115/60/1
Nema Plug (8' cord)	5-15P
<b>REFRIGERATION DATA</b>	
Horsepower	1/3
Capacity (BTU/Hr)	2800
Heat Rejection (BTU/Hr)	4200
Charge (lbs/grams/ounces)	0.3307 / 150 / 5.30
<b>SHIPPING DATA</b>	
Gross Weight (crated lbs)	791 lbs
Height - Crated	88"
Width - Crated	80"
Depth - Crated	36"

\*NOTE: Remote units are field wired and come with 6" legs. Refrigerant must be specified at time of order.

We reserve the right to change specifications and product design without notice. Such revisions do not entitle the buyer to corresponding changes, improvements, additions or replacements for previously purchased equipment. Dimensional tolerances +/- 1/4". Metric dimensions (MM).

## ELECTRICAL CONNECTION



115/60/1\*\*  
NEMA 5-15P

Unit pre-wired at factory and include 8' long cord and plug set.

\*\* NOTE: Units that utilize variable speed compressor technology can experience nuisance tripping on Class A GFCI outlets which have a trip limit of 4 to 6 mA. To avoid this issue in a location that requires GFCI circuit protection, Beverage-Air recommends using either an Eaton, SGF20, or HUBBELL Model Number GFRST83W 20A Heavy Duty Hospital Grade Self-Test GFCI Receptacle.

## Top Mount Reach-In Refrigerator Model: HR3HC-1HS

### Model Views

Required Clearance: Top 12" & Rear 3"

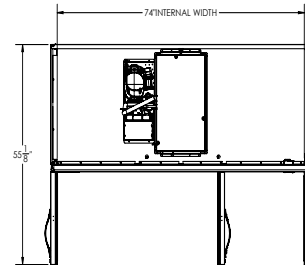

### PLAN VIEW

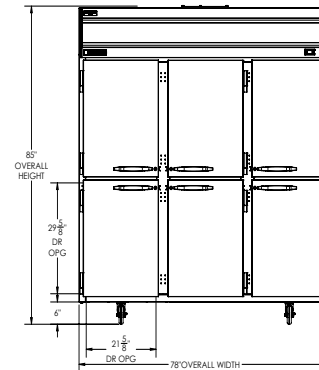

### ELEVATION VIEW

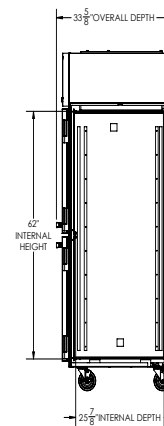

### SIDE VIEW

