



<b>IMPORTANT FOR FUTURE REFERENCE</b>	
Please complete this information and retain this manual for the life of the equipment:	
Model #:	_____
Serial #:	_____
Date Purchased:	_____

## Installation & Operation Manual

# TruVection Electric Convection Ovens TVES/10SC, TVES/20SC & TVES/30SC



Model TVES/10SC



Model TVES/20SC



Model TVES/30SC

### **WARNING**

Improper installation, adjustment, alteration, service or maintenance can cause property damage, injury or death. Read the installation, operating and maintenance instructions thoroughly before installing or servicing this equipment.

### **SOUTHBEND**

 **MIDDLEBY** A Middleby Company

1100 Old Honeycutt Road Fuquay-Varina, North Carolina 27526 USA

[www.southbendnc.com](http://www.southbendnc.com)



# SAFETY PRECAUTIONS

Before installing and operating this equipment, be sure everyone involved in its operation is fully trained and aware of precautions. Accidents and problems can be caused by failure to follow fundamental rules and precautions.

The following symbols, found throughout this manual, alert you to potentially dangerous conditions to the operator, service personnel, or to the equipment.



This symbol warns of immediate hazards that will result in severe injury or death.



This symbol refers to a potential hazard or unsafe practice that could result in injury or death.



This symbol refers to a potential hazard or unsafe practice that could result in injury, product damage, or property damage.



This symbol refers to information that needs special attention or must be fully understood, even though not dangerous.

 **WARNING**  
FIRE HAZARD  
FOR YOUR SAFETY

Do not store or use gasoline or other flammable vapors and liquids in the vicinity of this or any other appliance. Keep area around appliances free and clear of combustibles.

Purchaser of equipment must post in a prominent location detailed instructions to be followed in the event the operator smells smoke. Obtain the instructions from the local electrician/installer.

**NOTICE**

Be sure this Operator's Manual and important papers are given to the proper authority to retain for future reference.

**NOTICE**

This product is intended for commercial use only. NOT FOR HOUSEHOLD USE.

**NOTICE**

This manual should be retained for future reference.

Congratulations! You have purchased one of the finest pieces of heavy-duty commercial cooking equipment on the market.

You will find that your new equipment, like all Southbend equipment, has been designed and manufactured to meet the toughest standards in the industry. Each piece of Southbend equipment is carefully engineered and designs are verified through laboratory tests and field installations. With proper care and field maintenance, you will experience years of reliable, trouble-free operation. For best results, read this manual carefully.

RETAIN THIS MANUAL FOR FUTURE REFERENCE.

## Table of Contents

Specifications.....	4
Installation.....	8
Operation .....	17
Cooking Hints.....	20
Cleaning.....	23
Adjustments .....	25
Troubleshooting.....	29

Read these instructions carefully before attempting installation. Installation and initial startup should be performed by a qualified installer. Unless the installation instructions for this product are followed by a qualified service technician (a person experienced in and knowledgeable with the installation of commercial gas an/or electric cooking equipment) then the terms and conditions on the Manufacturer’s Limited Warranty will be rendered void and no warranty of any kind shall apply.

In the event you have questions concerning the installation, use, care, or service of the product, contact:

**Southbend Technical Service**  
 1100 Old Honeycutt Road  
 Fuquay Varina, North Carolina 27526 USA

The serial plate is located on the interior side of the lower front panel, as shown below.

FIGURE 1

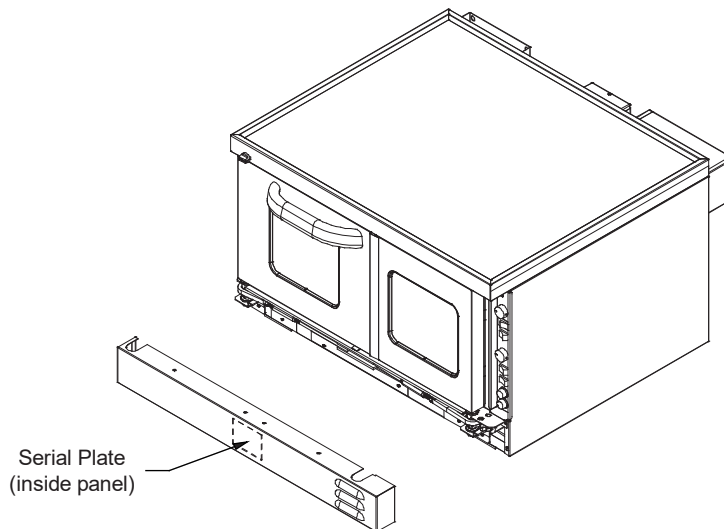

# SPECIFICATIONS

## NOTICE

The appliance, when installed, must be electrically grounded and comply with local codes, or in the absence of local codes, with the National Electrical Code, ANSI/NFPA 70, or the Canadian Electrical Code, CSA C22.2, as applicable.

Southbend reserves the right to change specifications and product design without notice. Such revisions do not entitle the buyer to corresponding changes, additions, or replacements for previously purchased equipment.

This product is intended for commercial use only, not for household use.

## ELECTRICITY SUPPLY

The following table lists the electricity supply requirements PER OVEN (double for dual-oven models; triple for triple-oven models).

SUPPLY VOLTAGE	OVEN COMPONENT	TOTAL KW	3-PHASE LOADING (kW/PHASE)			NOMINAL AMPERES PER LINE-WIRE				MINIMUM SUPPLY WIRE (AWG) SIZE	
			L1-L2	L2-L3	L1-L3	L1	L2	L3	1-PHASE TOTAL	3-PHASE	1-PHASE
480	Heating Elements	7.50	2.50	2.50	2.50	9.0	9.0	9.0	16.0	14	10
	Motor & Controls	0.90	0.00	0.00	0.90	2.2	0.0	2.2	2.2		
415	Heating Elements	7.50	2.50	2.50	2.50	10.4	10.4	10.4	18.1	12	10
	Motor & Controls	0.90	0.00	L1-N	0.90	0.0	0.0	3.8	3.8		
380	Heating Elements	7.50	2.50	2.50	2.50	11.4	11.4	11.4	20.0	12	8
	Motor & Controls	0.90	0.00	L1-N	0.90	0.0	0.0	4.1	4.1		
240	Heating Elements	7.50	2.50	2.50	2.50	18.0	18.0	18.0	31.3	10	8
	Motor & Controls	0.90	0.00	0.00	0.90	3.8	0.0	3.8	3.8		
220 (50Hz)	Heating Elements	7.50	2.50	2.50	2.50	19.7	19.7	19.7	34.1	10	8
	Motor & Controls	0.90	0.00	0.00	0.90	4.1	0.0	4.1	4.1		
208	Heating Elements	7.50	2.50	2.50	2.50	21.0	21.0	21.0	36.1	8	8
	Motor & Controls	0.90	0.00	0.00	0.90	4.3	0.0	4.3	4.3		

An electrical diagram is located on the side of the control panel assembly (see drawing on page 30). Electrical diagrams can also be found in this manual beginning on page 30.

The electrical connections are made directly to the terminals of the heating-element contactor, which is located inside the control-panel compartment on the right side of the oven. A circular opening sized for a strain-relief fitting is located on the back of the oven near the right side (right as seen from the front of the oven, see illustration on page 15). Models with two or three stacked ovens have a separate electrical connection for each oven.

Use 167°F (75°C) wire for all supply lines.

Ovens are shipped wired for either single-phase or three-phase operation, depending on which was specified on the factory order. If necessary, an oven can be field-converted to use either single-phase or three-phase power (see page 27).

# EXTERIOR DIMENSIONS

FIGURE 2

## Single-Deck Ovens

Dimensions are shown in inches and (millimeters)

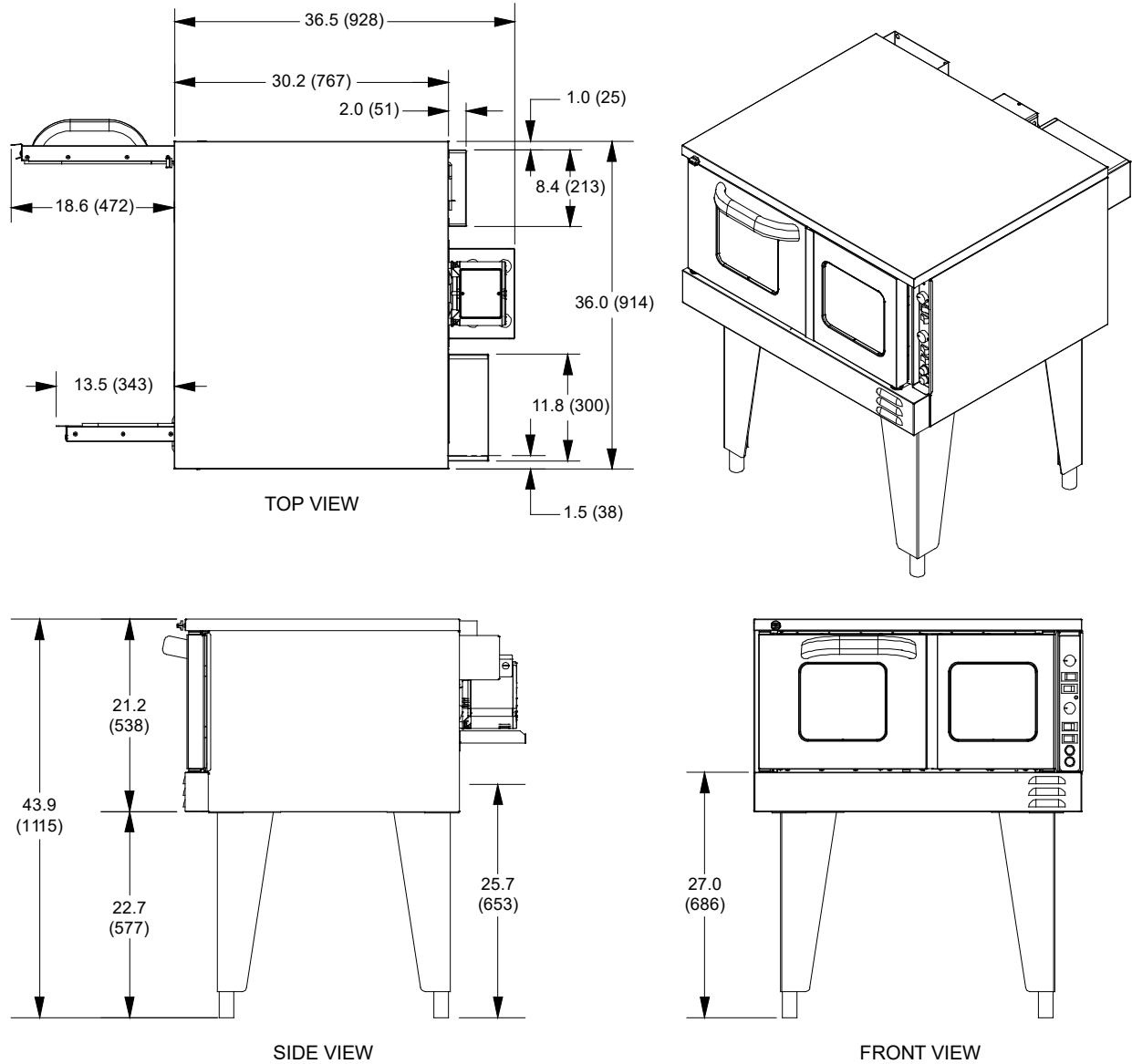

OVEN INTERIOR (PER DECK)			RACK CLEARANCE	
WIDTH	DEPTH	HEIGHT	WIDTH	DEPTH
29"	21.5"	14"	28.19"	21"

FIGURE 3

Double-Deck and Triple-Deck Ovens

Dimensions are shown in inches and (millimeters)

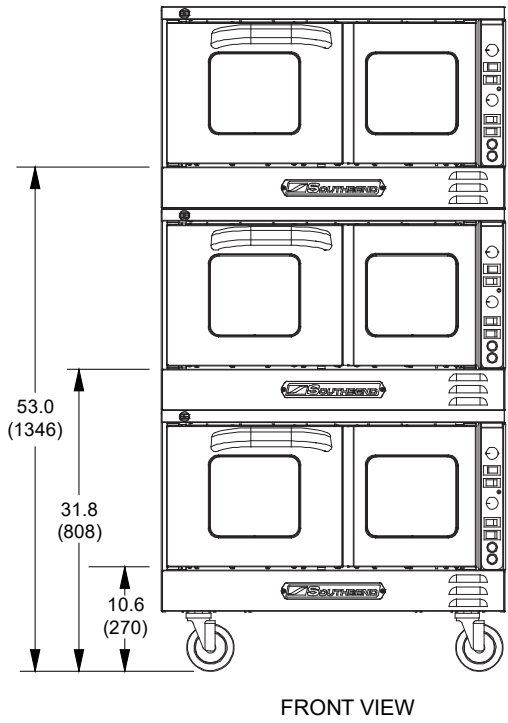
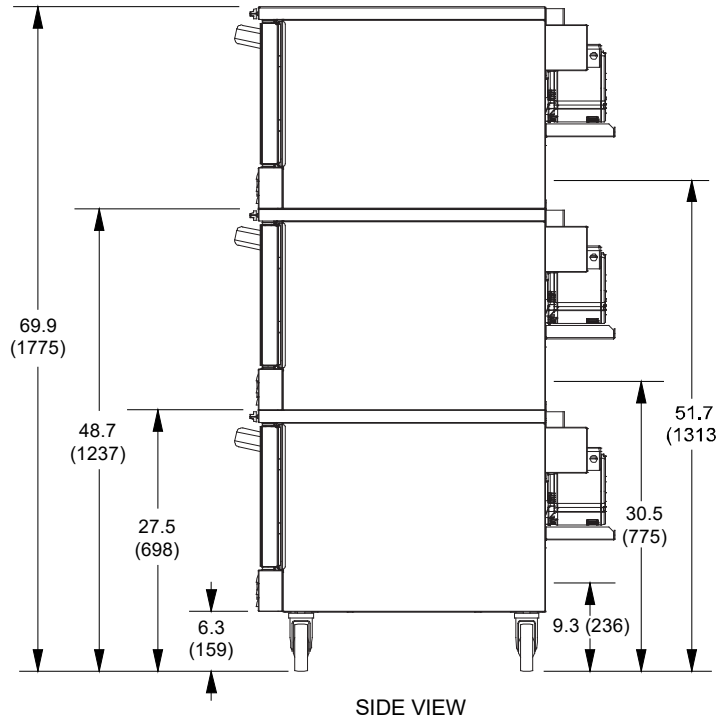
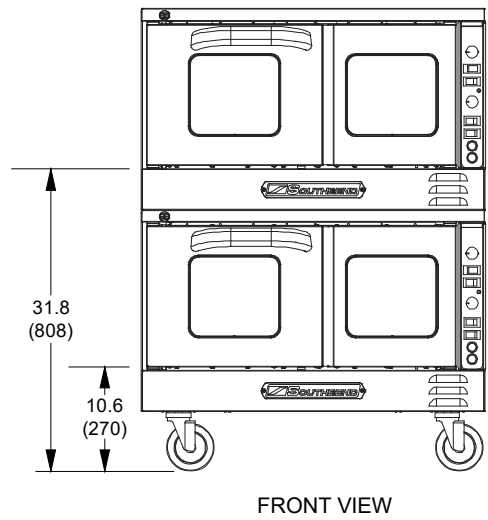
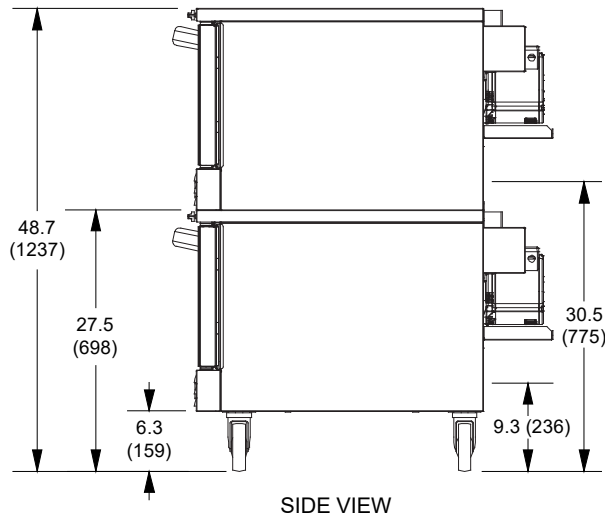

## MINIMUM CLEARANCES

 **WARNING**

	MINIMUM CLEARANCE FROM COMBUSTIBLE CONSTRUCTION	MINIMUM CLEARANCE FROM NON-COMBUSTIBLE CONSTRUCTION
Back	2"	2"
Right Side	0"	0"
Left Side	0"	0"
Floor	0"	0

Adequate clearance must be provided in the aisle to allow the doors to open sufficiently to permit the removal of the racks and for serviceability.

Although no clearance is required behind the motor on the rear of the oven, care must be taken to provide adequate air circulation to prevent the motor from overheating.

Do not locate the oven adjacent to any high heat or grease-producing piece of equipment, such as a range top, griddle, fryer, etc., that could allow radiant heat to raise the exterior temperature of the oven above 130°F (54°C). **DO NOT MOUNT ABOVE OTHER COOKING EQUIPMENT.**

## VENTILATION

**NOTICE**

Proper ventilation is the owner’s responsibility. Any problem due to improper ventilation will not be covered by the warranty.

The Southbend warranty does not require that electric TruVection ovens be installed under a ventilation canopy. However, local codes may require installation under a ventilation canopy.

If a ventilation canopy is used, it is recommended that a canopy extend 6” past the appliance and that the bottom edge be located 6’6” from the floor. Filters should be installed at an angle of 45° or more from the horizontal. This position prevents dripping grease and facilitates collecting the run-off grease in a drip pan, unusually installed with a filter.

If an exhaust fan is used, it should be installed at least 2” above the flue opening at the top of the unit. A strong exhaust fan tends to create a vacuum in the room. Fresh air openings approximately equal to the fan area will relieve such a vacuum. In case of unsatisfactory performance on any appliance, check the appliance with the exhaust fan in the “OFF” position. Do this only long enough to check equipment performance. Then turn the exhaust fan back on and let it run to remove any exhaust that may have accumulated during the test.

# INSTALLATION INSTRUCTIONS

## NOTICE

These installation procedures must be followed by qualified personnel or warranty will be void.

Local codes regarding installation vary greatly from one area to another. The National Fire Protection Association, Inc. states in its NFPA 96 latest edition that local codes are the “authority having jurisdiction” when it comes to installation requirements for equipment. Therefore, installations should comply with all local codes.

This appliance, when installed, must be electrically grounded in accordance with local codes, or in the absence of local codes, with the National Electrical Code, ANSI/NFPA 70 or the Canadian Electrical Code, CSA C22.2, as applicable.

## STEP 1: UNPACKING

### IMMEDIATELY INSPECT FOR SHIPPING DAMAGE

All containers should be examined for damage before and during unloading. The freight carrier has assumed responsibility for its safe transit and delivery. If damaged equipment is received, either apparent or concealed, a claim must be made with the delivering carrier.

Apparent damage or loss must be noted on the freight bill at the time of delivery. The freight bill must then be signed by the carrier representative (Driver). If the bill is not signed, the carrier may refuse the claim. The carrier can supply the necessary forms.

A request for inspection must be made to the carrier within 15 days if there is concealed damage or loss that is not apparent until after the equipment is uncrated. The carrier should arrange an inspection. Be certain to hold all contents plus all packing material.

1. Cut banding straps and remove packing material.
2. Remove tie-down strap holding oven to wooden skid.
3. If you are installing a single-deck oven, go to Step 2a.  
If you are installing a double-deck or triple-deck oven, go to Step 2b.



## STEP 2A: INSTALLATION OF LEGS ON SINGLE-DECK OVENS

1. Raise oven sufficiently to allow clearance for the legs to be attached. Use of a lift truck or other mechanical lifting means is recommended. For safety, "shore up" and support the oven with an adequate blocking arrangement strong enough to support the load. (If it is absolutely necessary to rest the oven on its side, rest it on its left side. Take care to protect the finish on the left side, and to prevent the weight from resting on the motor on the back.)
2. Attach the legs to the bottom corners of the oven using the provided machine screws, flat washers, and lock washers. Each leg is secured by five screws. The mounting holes are pre-drilled and threaded.
3. Screw into the bottom of each leg either an adjustable foot or a caster (depending on which option was ordered). If attaching casters, the two casters with brakes should be attached to the front legs.
4. Lower the oven gently onto a level surface. Never drop or allow the oven to fall.
5. Use a level to make sure that the oven is level. The adjustable feet can be screwed in or out to lower or raise each corner of the oven.
6. Go to Step 4 on page 15.

FIGURE 4

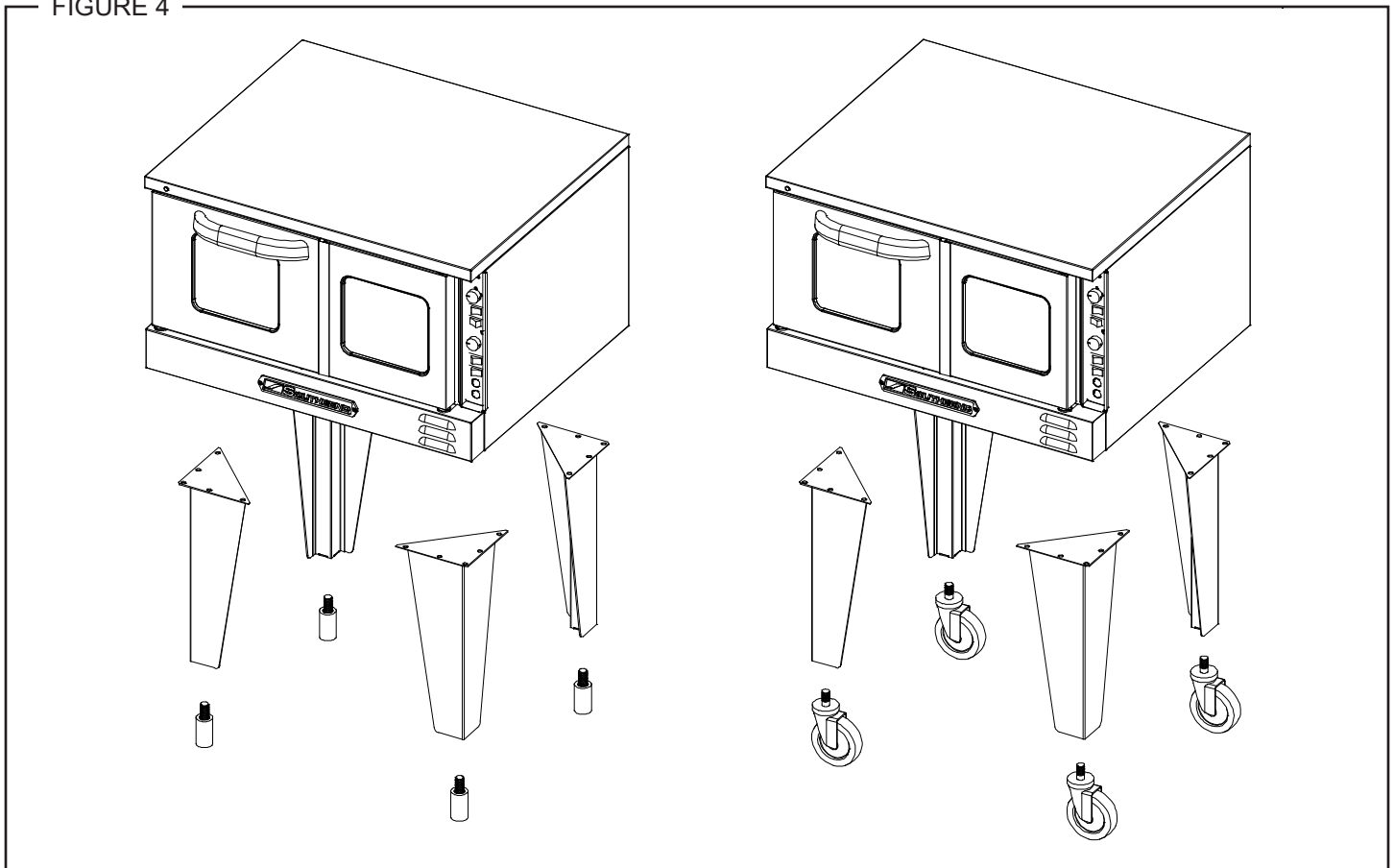

## STEP 2B: INSTALLATION OF LEGS ON DOUBLE-DECK OR TRIPLE-DECK OVENS

Double-deck (or triple-deck) ovens can be shipped either already bolted together, or as two (or three) separate ovens to be bolted together after delivery. In either case, the oven that is (or will be) the bottom oven will have leg pads already bolted to the bottom corners of the oven. Do the following:

1. Raise oven sufficiently to allow clearance for the legs to be attached. Use of a lift truck or other mechanical lifting means is recommended. For safety, "shore up" and support the oven with an adequate blocking arrangement strong enough to support the load. (If it is absolutely necessary to rest the oven on its side, rest it on its left side. Take care to protect the finish on the left side, and to prevent the weight from resting on the motor on the back.)
2. Screw into the center of each leg pad either an adjustable leg or a caster (depending on which option was ordered). If attaching casters, the two casters with brakes should be attached to the front leg pads.
3. Lower the oven gently onto a level surface. Never drop or allow the oven to fall.
4. Use a level to make sure that the oven is level. The adjustable legs can be screwed in or out to lower or raise each corner of the oven.

FIGURE 5

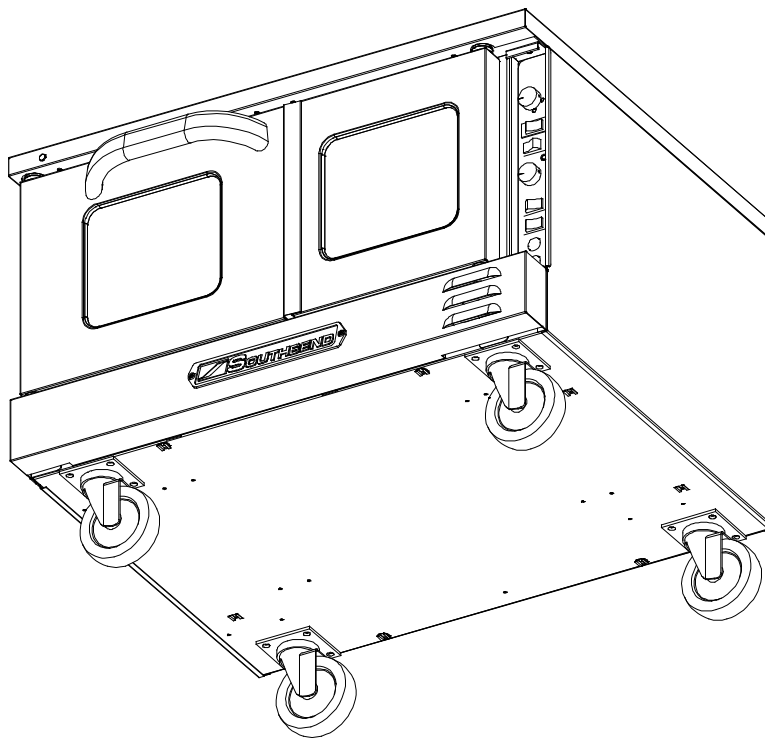

## STEP 3: INSTALLATION OF RESTRAINT (ONLY FOR OVENS WITH CASTERS)

### NOTICE

For an appliance equipped with casters, adequate means must be provided to limit the movement of the appliance without depending on or transmitting stress to the electrical conduit. The restraining means should be attached to a frame member on the back of the unit and the appliance should be installed using flexible conduit.

1. Secure the restraining-device bracket (item "B" in the following illustration) to a wall stud located as close as possible to the appliance connector inlet and outlet connections. Use four #12 screws (items "C") and plastic anchors (items "A") if necessary.

FIGURE 6

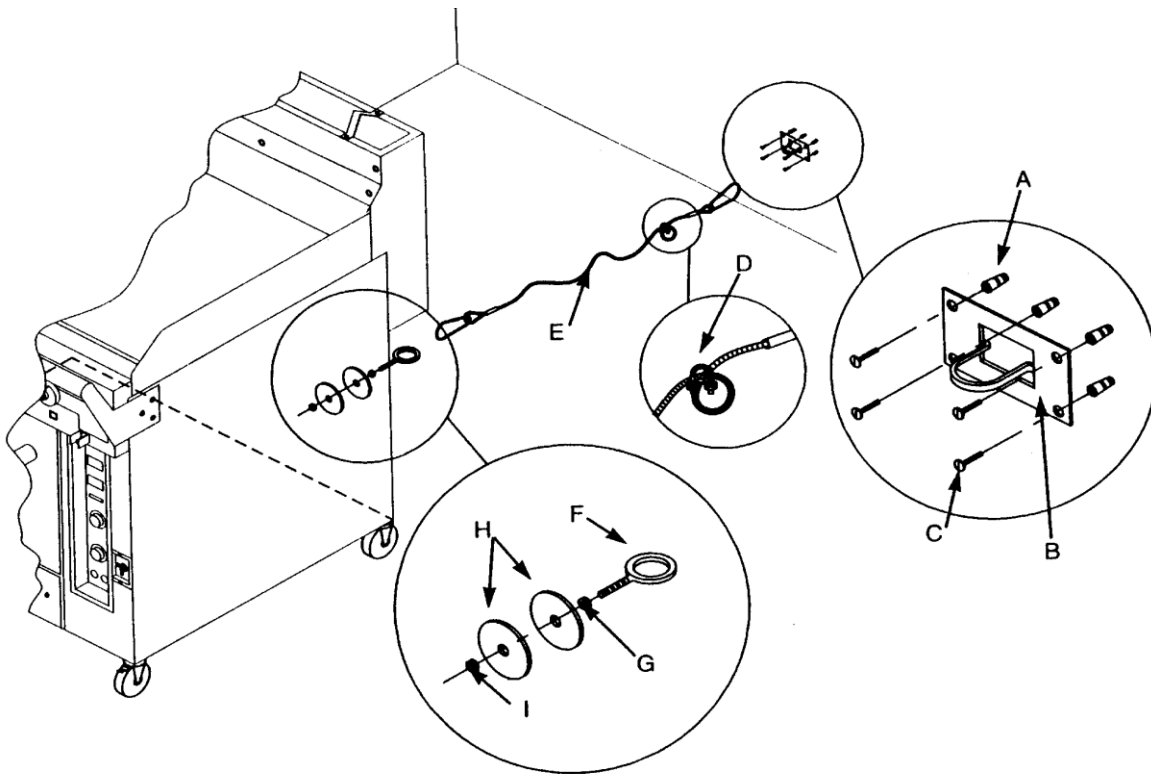

Note: Kit can be purchased from Southbend (part number 1176867).

2. Install eye-bolt (item "F") to a frame member on the rear of the equipment. After checking carefully behind the frame member for adequate clearance, drill a 1/4" hole through the frame member.
3. Thread hex nut (item "G") and slide the washer (item "H") onto the eye-bolt. Insert the eye-bolt through the 1/4" drilled hole and secure with a washer (item "H") and nylon lock nut (item "I").
4. Using the spring-loaded snap hooks, attach the restraining device to the bracket and the eye-bolt.
5. Using the cable clamp (item "D"), adjust the restraining device extended length to prevent over-bending or kinking of the appliance connector.

## STEP 4: STACK OVENS (IF NECESSARY)

Double-deck (or triple-deck) ovens can be shipped already assembled, but can instead be shipped as two (or three) single-deck ovens to be stacked in the field. Also, ovens that were originally ordered as single ovens can be stacked in the field (additional parts are required). This installation step describes the procedure for stacking two single-deck ovens to form a double-deck oven. For a triple-deck oven, repeat this step.

1. Uncrate the ovens. Identify the oven that will be the bottom unit (it will be the oven with pads attached to the bottom corners). Attach the legs (or casters), to the lower oven as described in Step 2b on page 10.
2. If the oven that will be the top unit was NOT ordered as part of a double-deck or triple-deck oven, remove the four mounting legs or casters from the bottom of that oven.
3. Locate and remove the four screws that secure the front panel, (items "A" in the drawing below). Lift up the panel and pull it forward to remove it, then set it aside.

FIGURE 7

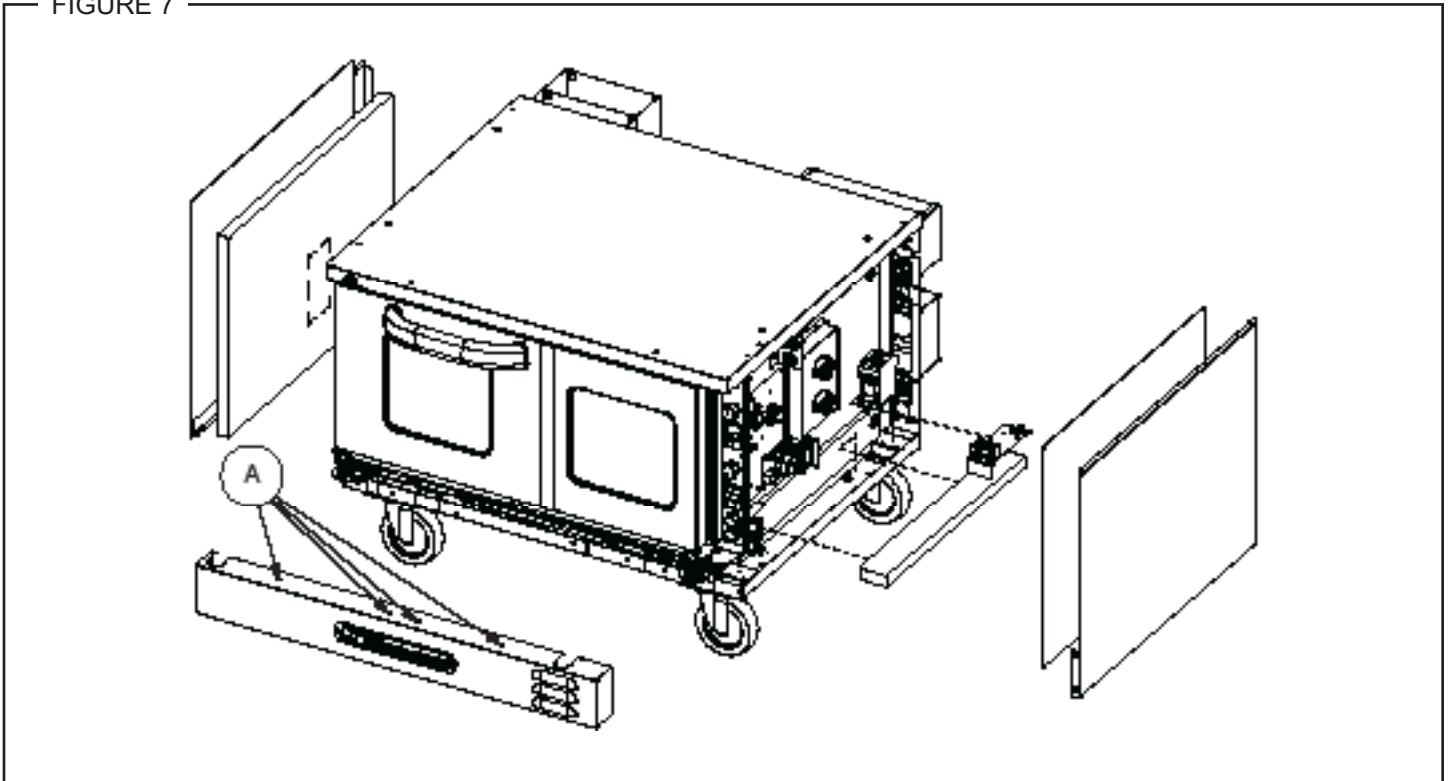

4. Locate and remove the screws that secure the left and right side panels to the oven. Remove panels and insulation and set them aside as shown in the picture above.
5. Remove the terminal block mounting plate and lower insulation strip on right side of unit for access to holes.
6. If the oven that will be the bottom unit was NOT ordered as part of a double-deck or triple-deck oven, holes will need to be drilled in the existing top, or an optional mounting top can be ordered. The panel sides and insulation will also need to be removed from lower oven to allow access for bolting the units together.

- Lift the top oven onto the lower oven and position it as shown in the drawing below.

FIGURE 8

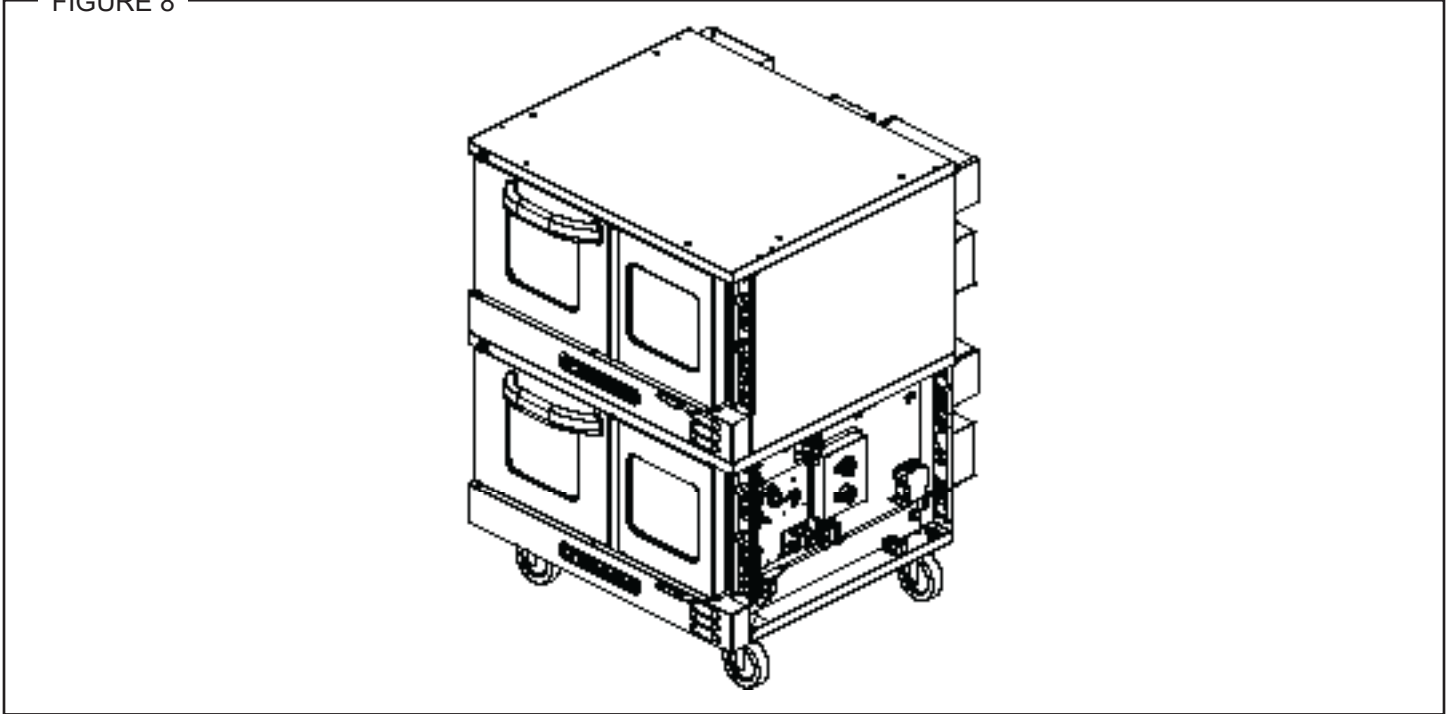

- Move to the rear of the ovens and remove the six screws shown as items "A" in the left-hand drawing below. Position the tie bracket (item "B") as shown in the right-hand drawing below. Re-insert the screws that you just removed through the holes in the tie bracket, but do not tighten them yet.

FIGURE 9

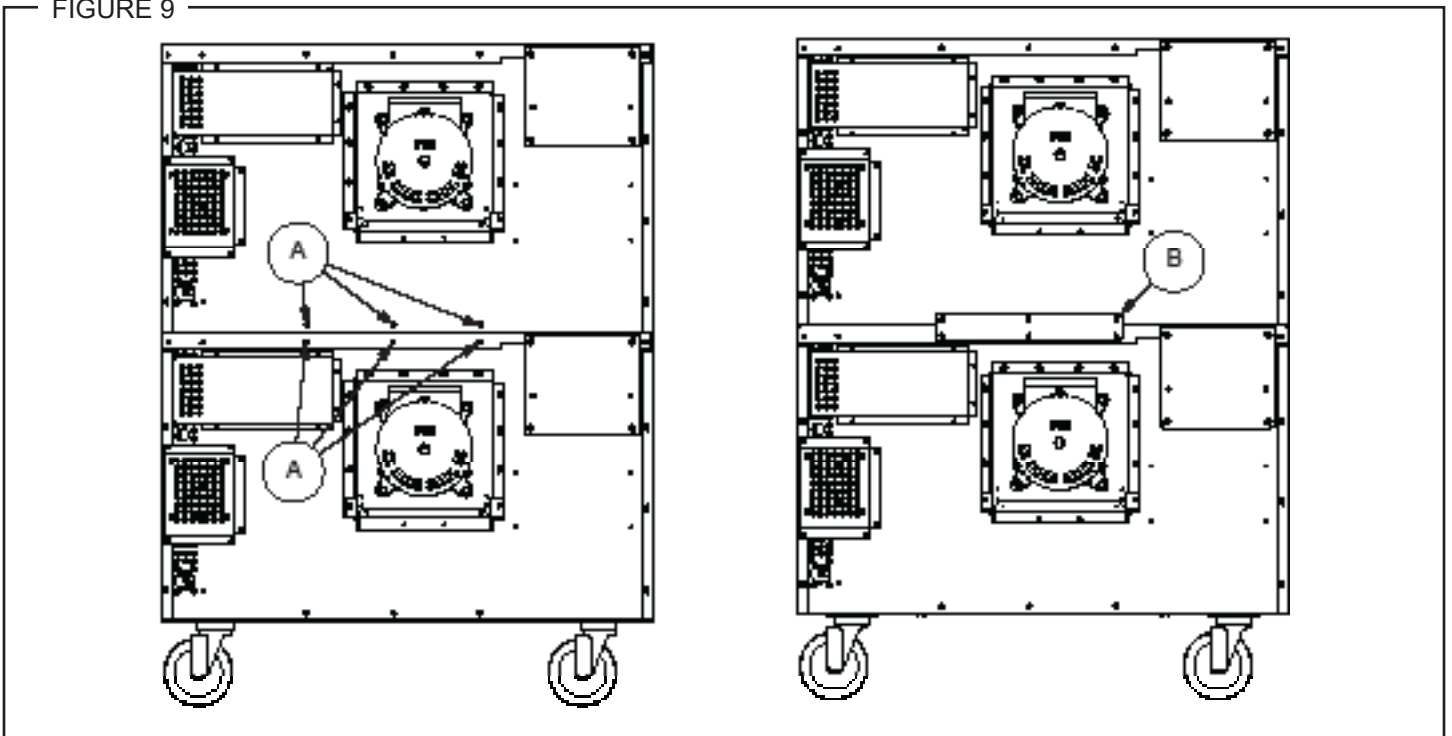

9. Insert two 1/4-20 bolts on each side (items "A" in the following diagram), as shown in the pictures below. Screw them down into the threaded inserts of the optional mounting top on the lower unit, or use a bolt and nut to secure if holes were manually drilled.

FIGURE 10

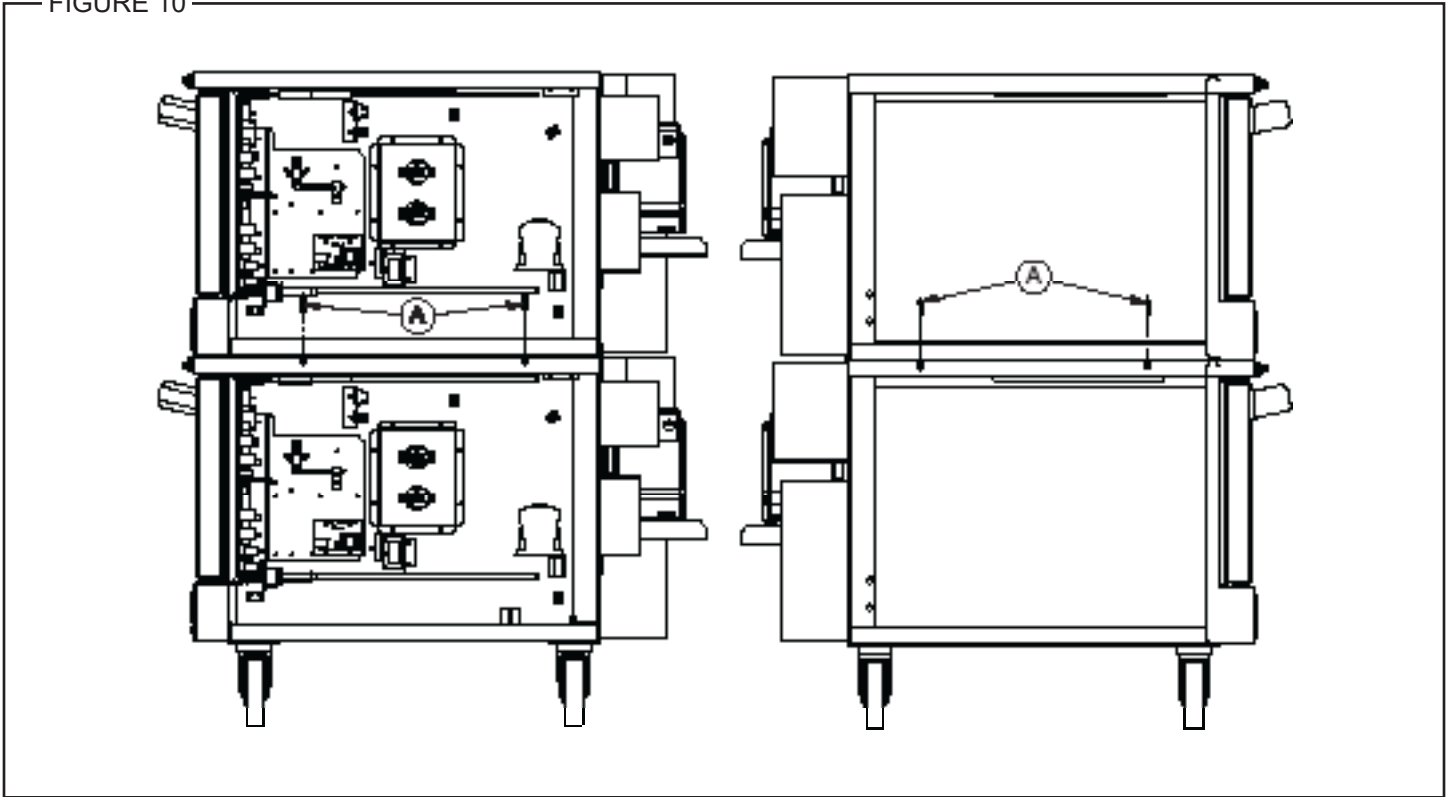

10. Reinstall Terminal Block Mounting Plate, insulation, exterior side panels and lower front panel that were removed in Steps 3, 4, & 5 of this procedure.

## STEP 5: CONNECT ELECTRICITY SUPPLY

### WARNING

#### ELECTRICAL GROUNDING INSTRUCTIONS

This appliance, when installed, must be electrically grounded in accordance with local codes, or in the absence of local codes, with the National Electrical Code, ANSI/NFPA 70 or the Canadian Electrical Code, CSA C22.2, as applicable.

Ovens are shipped wired for either single-phase or three-phase power according to the original factory order. Wiring diagrams are located on the side of the control panel assembly, as well as in this manual (beginning on page 30). Be sure that the input voltage and phase match the requirements shown on the serial plate, which is located inside the lower front panel.

Conversion between single-phase and three-phase power can be performed in the field (see page 27).

The oven must be adequately grounded.

Use 167°F (75°C) wire for all supply lines.

The following drawing shows the locations of items referred to in the following procedure.

FIGURE 11

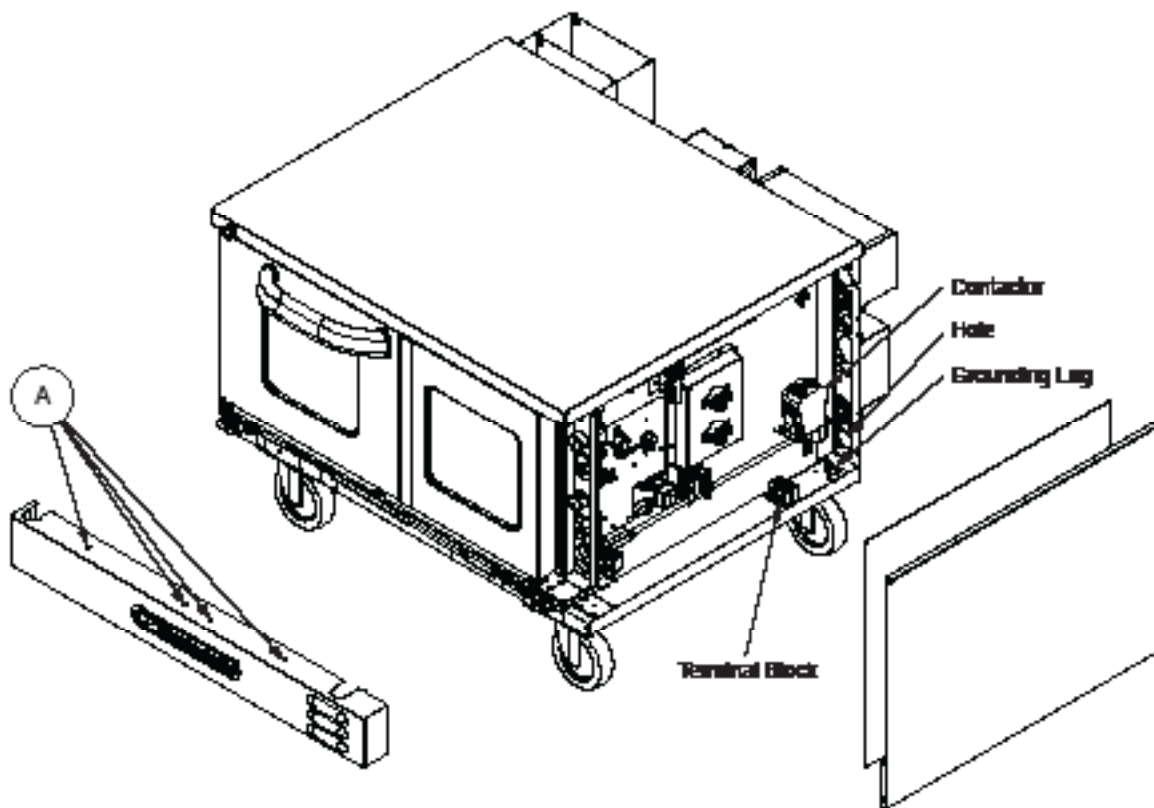

1. CHECK THAT THE POWER SUPPLY CIRCUIT BREAKER IS OPEN.
2. Locate and remove the four screws that secure the lower front panel (items "A" in the drawing above). Lift up the panel and pull it forward to remove it, then set it aside.
3. To connect the supply wires, locate and remove the five screws (3 back, 2 front), that secure the right side panel to the oven.

4. Route the supply wires and the grounding wire through the hole on the back of the oven. Use a strain-relief fitting.
5. Attach each supply wire to the appropriate terminal of the contactor or terminal block (according to the wiring diagrams starting on page 30), taking care not to disconnect any wires that may already be connected to the contactor or terminal block.
6. Insert the ground wire into the grounding lug and tighten the screw.
7. Check that all connections match the wiring diagram and are tight.
8. Reattach the right-side panel and insulation; and the lower-front panel.

## STEP 6: CHECK THE INSTALLATION

1. Check that all screws and bolts are tightened.
2. Move the oven into the position at which it will be operated.
3. Check that the oven is level. If not, adjust the legs.
4. Check that the appropriate clearances are satisfied (see page 7).
5. Turn-on supply power and check oven for proper operation.



# OPERATING INSTRUCTIONS

## OPERATING THE CONTROLS

A convection oven is a different type of oven that offers many features and advantages to the food service operation. The additional capabilities and features of the oven require some learning. However, the operation of the oven is not difficult to understand or control once you have some practice.

## MOISTURE VENT

Each oven has a moisture vent that is opened and closed using the small knob located near the top left corner of the front panel of the oven (see illustration below). Usually the vent is kept open to allow moisture to escape. Close the vent (turn the knob clockwise) when doing fine baking.

FIGURE 12

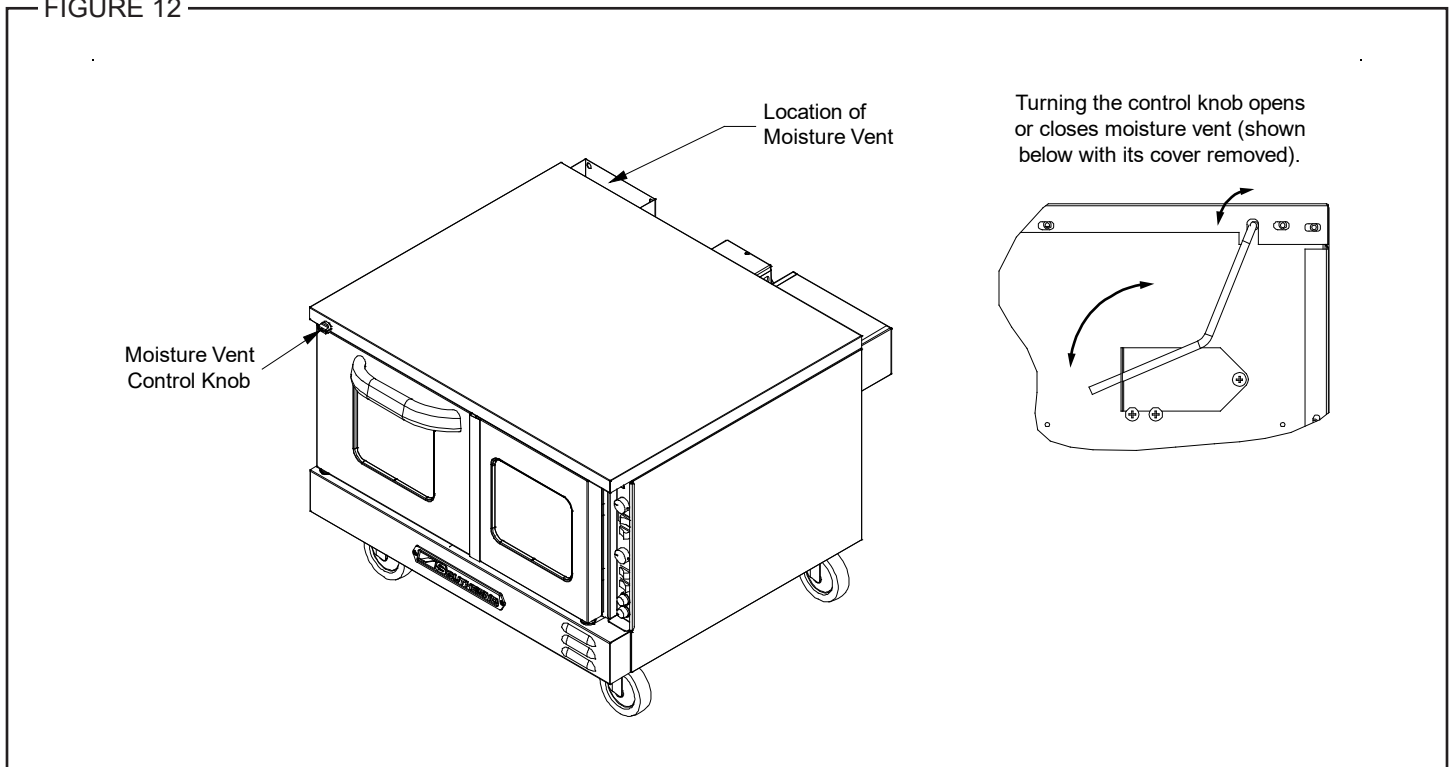

CONTROL PANEL

FIGURE 13

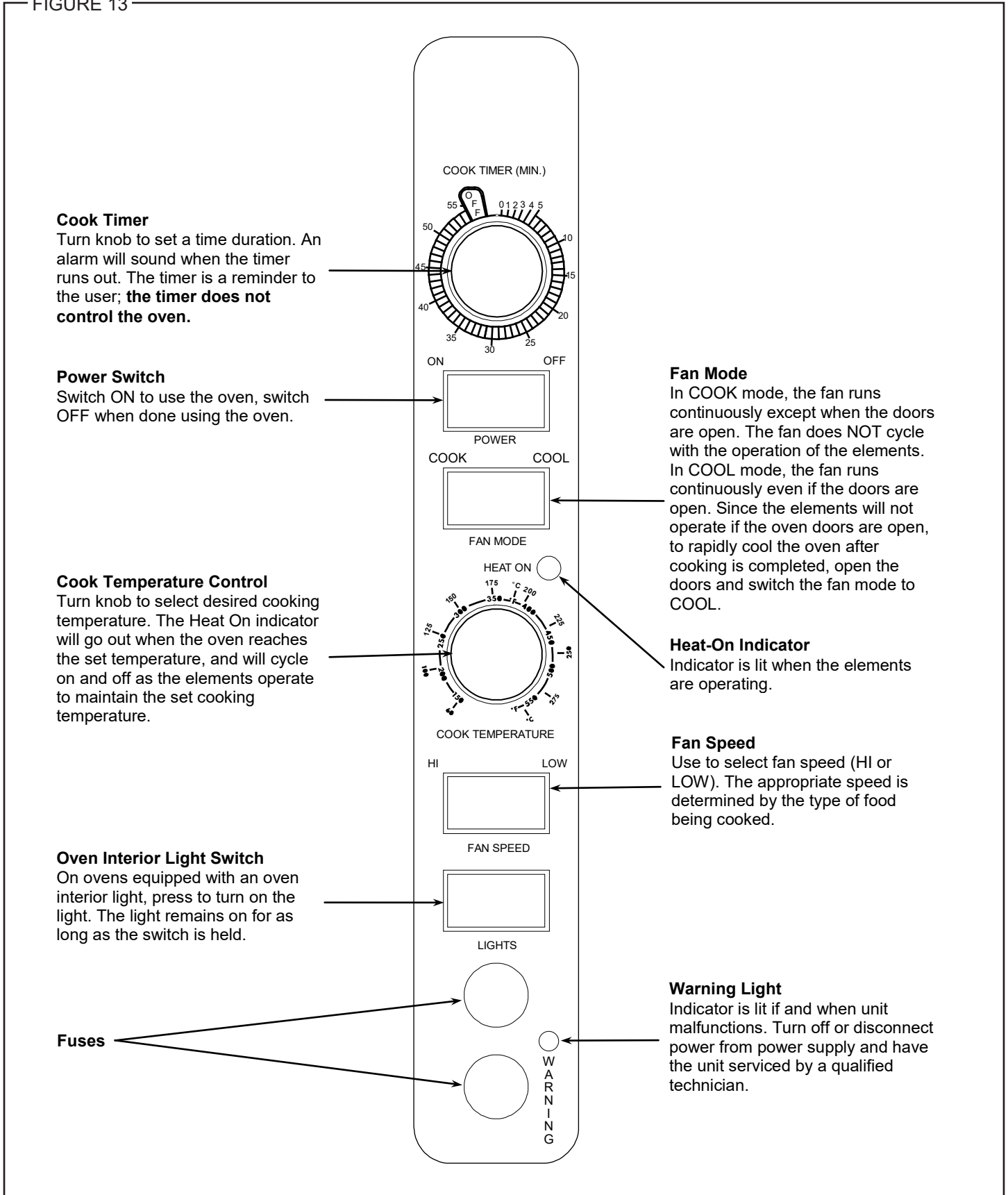

**Cook Timer**  
Turn knob to set a time duration. An alarm will sound when the timer runs out. The timer is a reminder to the user; **the timer does not control the oven.**

**Power Switch**  
Switch ON to use the oven, switch OFF when done using the oven.

**Cook Temperature Control**  
Turn knob to select desired cooking temperature. The Heat On indicator will go out when the oven reaches the set temperature, and will cycle on and off as the elements operate to maintain the set cooking temperature.

**Oven Interior Light Switch**  
On ovens equipped with an oven interior light, press to turn on the light. The light remains on for as long as the switch is held.

**Fuses**

**Fan Mode**  
In COOK mode, the fan runs continuously except when the doors are open. The fan does NOT cycle with the operation of the elements. In COOL mode, the fan runs continuously even if the doors are open. Since the elements will not operate if the oven doors are open, to rapidly cool the oven after cooking is completed, open the doors and switch the fan mode to COOL.

**Heat-On Indicator**  
Indicator is lit when the elements are operating.

**Fan Speed**  
Use to select fan speed (HI or LOW). The appropriate speed is determined by the type of food being cooked.

**Warning Light**  
Indicator is lit if and when unit malfunctions. Turn off or disconnect power from power supply and have the unit serviced by a qualified technician.

 **WARNING**

If the malfunction light turns on, the appliance is malfunctioning. Turn off or disconnect power from power supply and have the unit serviced by a qualified technician.

TruVection ovens operate much like a standard oven: you turn the oven ON and select a cooking temperature. Two additional controls are used to control the fan (as described below).

The timer is a reminder to you of when to remove food from the oven. The timer does NOT control the temperature of the oven.

To cook, do the following:

1. Turn the oven ON using the Power Switch at the top of the control panel.
2. Select the desired fan speed using the Fan Speed switch. The appropriate fan speed (HI or LOW) depends on the type of food being cooked.
3. Switch the Fan Mode switch to COOK. The fan will run continuously when the oven doors are closed (the fan does not cycle on and off with the elements). (If this switch is set to COOL the only difference is that the fan will continue to run when the oven doors are open.)
4. Set the cooking temperature by turning the Cook Temperature Control until the indicator mark on the knob is pointed to the desired cooking temperature. The Heat On indicator will light when the elements are on, and will remain on while the oven preheats.
5. Wait until the Heat On indicator has come on and gone out three times. At that time the oven will have reached the set cooking temperature.
6. Open the oven doors, load the product into the oven, and close the doors.
7. You can use the Cook Timer as a reminder of when to remove the load from the oven. If so desired, turn the Cook Timer knob until the indicator mark points to the desired cooking time (up to 55 minutes). The timer knob will rotate counterclockwise as the timer runs down, indicating how much time remains. You can turn the knob while cooking to increase or decrease the remaining time. When the timer runs out, a buzzer will sound for a short time, then turn itself off. (To immediately silence the buzzer, turn the Cook Timer knob to the OFF position.) The timer is a reminder to you; the timer does not control the oven.

If you open the oven doors while in COOK mode, the elements and fan will shut off until the doors are closed. However, the timer will continue running even if the doors are open.

For ovens that are equipped with an oven interior light, to turn on the light press and hold the switch located at the bottom of the control panel.

8. When the load has finished cooking, you can rapidly cool the load by opening the oven doors (which will shut off the elements) and switching the Fan Mode to COOL (which will cause the fan to run even though the doors are open). For the most rapid cooling, also switch the Fan Speed switch to HI.
9. When you are done cooking, turn the Cook Temperature control to the lowest setting (fully counterclockwise) and switch the Power Switch to OFF.

# COOKING HINTS

In a standard (non-convection) oven, the air is relatively still and an insulating layer of moisture surrounds the cooking food product. In a convection oven, the fan-blown circulating air strips away this insulating layer allowing the heat to penetrate faster for quicker baking and roasting. Hence, in a convection oven cooking procedures and techniques may require some modification for successful results. As a general rule, the cooking time will be shorter and the cooking temperature will be 25°F to 75°F lower than those called for in recipes for a standard oven.

## TIME & TEMPERATURE

Time and temperature are important. The “Guide to Times and Temperatures” later in this section is a starting point. The actual best cooking time and temperature will depend on such factors as size of load and mixture of recipe (particularly moisture). Once an appropriate time and temperature has been established for a particular product and load, you will find the result of succeeding loads to be similar.

## OVERLOADING

Do NOT overload the oven. The size of the load that can be cooked satisfactorily depends largely on the particular product. As a rule, three racks can be successfully used for shallow cakes, cookies, pies, etc. For deeper cakes (such as angel food), use only one or two racks because of the size of the pan and the space required for rising. For hamburger patties, fish sticks, cheese sandwiches, etc., three or four racks and pans is usually satisfactory.

## HELPFUL SUGGESTIONS

Here are some suggestions that will assist in getting the best possible performance from a convection oven:

- Pre-heat the oven thoroughly before use.
- When re-thermalizing frozen products, pre-heat the oven to 50°F higher than the planned cooking temperature. After loading, reduce the temperature setting to the appropriate cooking temperature.
- Space the racks and pans as evenly as possible to allow air circulation.
- Center the load on the racks to allow for proper air circulation around the sides. Do not cover the racks completely with pans.
- Do not use a deep pan for shallow cakes or cookies, etc. Air circulation across the surface of the product is essential.

### **WARNING**

THE USE OF ALUMINUM FOIL CAN CAUSE HEAT DISTRIBUTION PROBLEMS IN OVENS. EXTREME CARE MUST BE USED WHEN PLACING ALUMINUM FOIL IN THE OVEN TO ENSURE THAT IT DOES NOT BLOCK OR CHANGE THE AIR FLOW. THE USE OF ALUMINUM FOIL MAY VOID THE PRODUCT WARRANTY IF ITS USE IS ASCERTAINED TO BE A PROBLEM.

## COOKING PROBLEMS AND SOLUTIONS

If...	then...
Cakes are dark on the sides and not done in the center...	lower oven temperature.
Cake edges are too brown...	reduce number of pans or lower oven temperature.
Cakes have a light outer color...	raise temperature.
Cakes settle slightly in the center...	bake longer or raise oven temperature slightly. Do not open doors except to load or unload product.
Cakes ripple...	do not overload pans or use batter that is too thin.
Cakes are too coarse...	lower oven temperature.
Pies have uneven color...	reduce number of pies per rack or eliminate use of bake pans.
Brown sugar topping or meringue blows off...	after oven is preheated, turn off oven and put product in oven until topping sets, then turn oven back on.
Rolls have uneven color...	reduce number or size of pans.
Meats are browned and not done in center...	lower oven temperature and roast longer.
Meats are well done and not browned...	raise temperature. Limit amount of moisture.
Meats develop hard crust...	reduce temperature or place pan of water in oven.
Excessive meat shrinkage occurs...	lower oven temperature.

## GUIDE TO TIMES AND TEMPERATURES

As a guide, set oven temperatures 25°F to 75°F lower than called for in recipes for non-convection ovens, (i.e., range or deck ovens).

Time and temperature will vary depending upon load, mix, size, portion, initial temperature of food, and other factors. Use the following chart as a starting point to develop your own cooking techniques. Rack loading and position may affect results. Experimentation may be necessary to suit individual requirements.

PRODUCT	COOKING TIME	TEMPERATURE	NUMBER OF RACKS
MEAT AND FISH			
Top Round, 18-20 lbs. (medium)	5 hours	225°F	1
Prime Ribs (rare)	4 hours	225°F	1
Burger Patties, 4 oz.	5 min.	350°F	3
Fish Cakes	10-12 min.	350°F	3
Turkey, 10-12 lbs.	3 hours	225°F	1

PRODUCT	COOKING TIME	TEMPERATURE	NUMBER OF RACKS
<b>BAKED GOODS</b>			
Bread, 2 lb. loaf	35 min.	375°F	2
Biscuits	5-10 min.	350°F	3
Combread	18 min.	400°F	3
French Bread	8 min.	375°F	2
Sheet Cake	15-18 min.	300°F	3
Cream Puffs	20 min.	325°F	3
Brown & Serve Rolls	5 min.	400°F	3
Ginger Bread	18 min.	300°F	3
Yeast Rolls, sheet pan	14-16 min.	325°F	2
Pineapple Upside Down Cake	25-30 min.	300°F	2
Apple Turnovers	15-18 min.	325°F	3
Fruit Cobbler	20-23 min.	350°F	2
Brownies	15 min.	350°F	3
Danish Pastry	12 min.	325°F	3
Pie Shells	12 min.	350°F	2
Fresh Fruit Pies	25-30 min.	350°F	2
Pumpkin Pies	25-30 min.	275°F	2
Fresh Apple Pies	35 min.	375°F	2
Frozen Berry Pies	40 min.	375°F	2
Frozen Fruit Pies	45 min.	375°F	2
<b>POTATOES</b>			
Baked Potatoes, 10 oz.	40-45 min.	450°F	2
Baked Potatoes, 6-8 oz.	30-35 min.	450°F	3
Scalloped Potatoes	28 min.	325°F	3
<b>MISCELLANEOUS</b>			
Macaroni and Cheese	25 min.	350°F	2
Stuffed Peppers	18 min.	350°F	3
Toasted Cheese Sandwiches	8 min.	375°F	3

# CLEANING

Southbend equipment is sturdily constructed of the best materials and is designed to provide durable service when treated with ordinary care. To expect the best performance, your equipment must be maintained in good condition and cleaned daily. Naturally, the periods for this care and cleaning depend on the amount and degree of usage.

Following daily and periodic maintenance procedures will enhance long life for your equipment. Climatic conditions (such as salt air) may require more thorough and frequent cleaning or the life of the equipment could be adversely affected.

The oven interior is finished with a porcelain enamel coating. "Spillovers" should be cleaned from the interior bottom surface as soon as possible to prevent carbonizing and a burnt-on condition. Grease or any residue should be cleaned from interior surfaces as soon as it accumulates.

## WARNING

FOR YOUR SAFETY, DISCONNECT THE POWER SUPPLY TO THE APPLIANCE BEFORE CLEANING.

WHEN CLEANING THE BLOWER WHEEL, BE SURE TO HAVE THE POWER SWITCH IN THE "OFF" POSITION.

## DAILY CLEANING

1. Turn the power switch to OFF and allow the oven to cool.
2. Remove the oven-interior racks and rack slide frames. (The rack slide frames are readily removable by merely raising to disengage them from their sockets.) Wash the racks and rack slides in a sink with mild detergent and warm water. Dry them thoroughly with a clean cloth.
3. Look to see if any foreign matter has accumulated on the blades of the blower wheel (which will reduce air circulation). If necessary, remove the rear lining of the oven, which is secured by thumbscrews near each corner. Use a stiff brush to remove accumulations from the blower blades, then wash with soap and water.
4. Wash the interior surfaces with mild detergent and warm water. Rinse with clean water, and dry thoroughly with a clean cloth. For stubborn accumulations, a commercial oven cleaner may be used.
5. Clean the control panel with warm water and mild soap. Never use cleaning solvents with a hydrocarbon base.
6. Wipe the other exterior surfaces with a clean damp cloth. If the exterior surfaces require more thorough cleaning, see "Cleaning Stainless Steel Surfaces" on the next page.
7. Return the rack slides and racks to their appropriate locations inside the oven.
8. LEAVE THE DOOR OPEN AT NIGHT AFTER CLEANING. This allows the oven to dry thoroughly after cleaning and also prolongs the life of the door gasket.

## MONTHLY CLEANING

Clean around rear of motor (where the vent screen is located), louvered panels, and air holes in the rear of the oven where grease or lint may have accumulated.

## SEMIANNUAL CLEANING

At least twice a year have your Southbend Authorized Service Agency or another qualified service technician clean and adjust the unit for maximum performance.

At least twice a year the oven's venting system should be examined and cleaned.

## CLEANING STAINLESS STEEL SURFACES

To remove normal dirt, grease and product residue from stainless steel that operates at LOW temperature, use ordinary soap and water (with or without detergent) applied with a sponge or cloth. Dry thoroughly with a clean cloth.

To remove grease and food splatter, or condensed vapors, that have BAKED on the equipment, apply cleanser to a damp cloth or sponge and rub cleanser on the metal in the direction of the polishing lines on the metal. Rubbing cleanser, as gently as possible, in the direction of the polished lines will not mar the finish of the stainless steel. NEVER RUB WITH A CIRCULAR MOTION. Soil and burnt deposits which do not respond to the above procedure can usually be removed by rubbing the surface with SCOTCH-BRITE scouring pads or STAINLESS scouring pads. DO NOT USE ORDINARY STEEL WOOL, as any particles left on the surface will rust and further spoil the appearance of the finish. NEVER USE A WIRE BRUSH, STEEL SCOURING PADS (EXCEPT STAINLESS), SCRAPER, FILE OR OTHER STEEL TOOLS. Surfaces which are marred collect dirt more rapidly and become more difficult to clean. Marring also increases the possibility of corrosive attack. Refinishing may then be required.

To remove heat tint – Darkened areas sometimes appear on stainless steel surfaces where the area has been subjected to excessive heat. These darkened areas are caused by thickening of the protective surface of the stainless steel and are not harmful. Heat tint can normally be removed by the foregoing, but tint which does not respond to this procedure calls for a vigorous scouring in the direction of the polish lines, using SCOTCH-BRITE scouring pads or a STAINLESS scouring pad in combination with a powered cleanser. Heat tint action may be lessened by not applying, or by reducing heat to equipment during slack periods.



# Adjustments

## WARNING

ADJUSTMENTS AND SERVICE WORK MAY BE PERFORMED ONLY BY A QUALIFIED TECHNICIAN WHO IS EXPERIENCED IN, AND KNOWLEDGEABLE WITH, THE OPERATION OF COMMERCIAL COOKING EQUIPMENT. HOWEVER, TO ASSURE YOUR CONFIDENCE, CONTACT YOUR AUTHORIZED SERVICE AGENCY FOR RELIABLE SERVICE, DEPENDABLE ADVICE OR OTHER ASSISTANCE, AND FOR GENUINE FACTORY PARTS.

## NOTICE

Warranty will be void and the manufacturer is relieved of all liability if service work is performed by other than a qualified technician, or if other than genuine Southbend replacement parts are installed.

## LUBRICATION

The door chains and sprockets have been lubricated at the factory with high temperature “Never Seeze” lubricant. After each six months of usage, lubricate the door chains and sprockets with the same type of lubricant.

Motor lubrication information can be found on permanent label located on motor.

## ADJUSTING DOOR CHAIN MECHANISM

The door chain mechanism causes the left and right doors to open and close together. To adjust the door chain mechanism, do the following:

1. Remove lower front panel that covers the door chain mechanism (shown below).
2. Close both doors.
3. Check the positioning of the chain on the sprockets. There should be five regular links and one master link visible on the front side of each chain. If not, open the turnbuckles and reposition the chain over the sprockets.
4. Adjust the turnbuckles so that the right door closes about 1/4” to 1/2” inch ahead of the left door. The left door should be pushed tight over the friction catch so both doors are completely closed against the frame.
5. Secure the turnbuckles by tightening their locknuts.

FIGURE 14

## Door Chain Adjustment

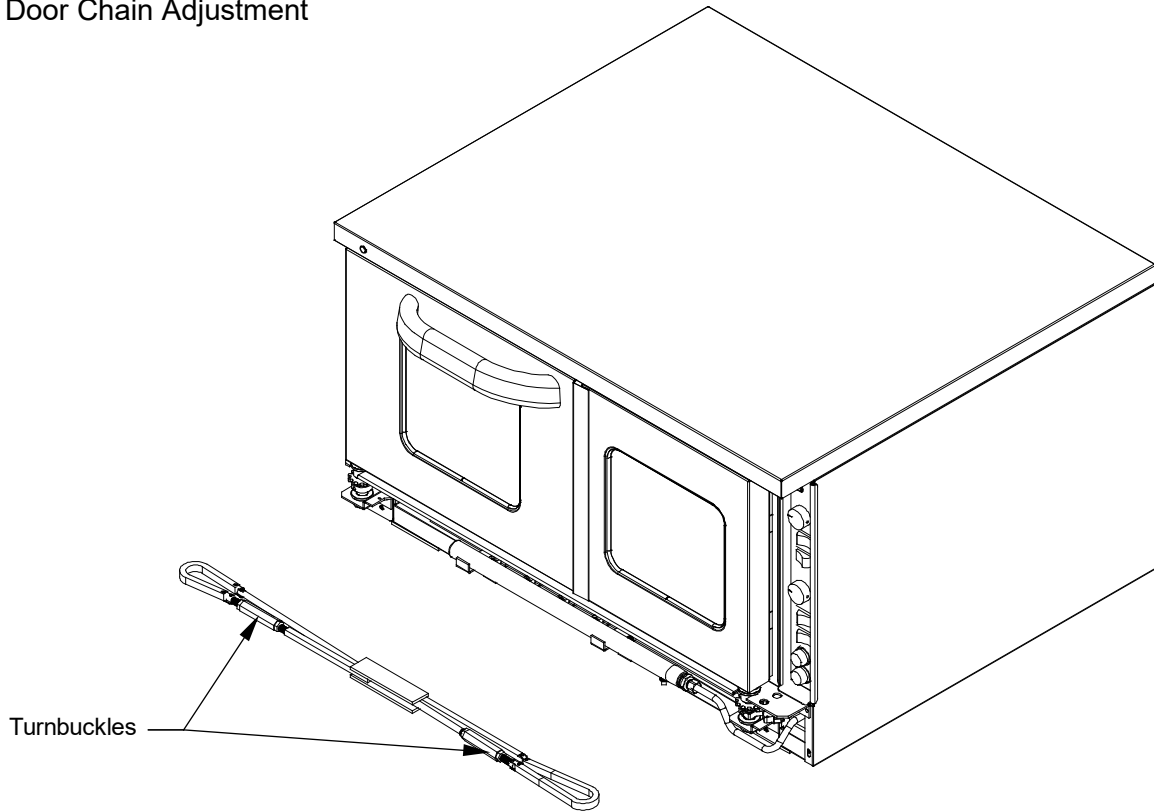

## TEMPERATURE CONTROLLER

The calibration of the temperature controller should not be changed until sufficient experience with cooking results has definitely proved that the temperature controller is not maintaining proper oven temperatures. Before any recalibration is attempted, the oven temperature should be checked by the following procedure:

1. Remove all trays and pans from the oven.
2. Place a thermocouple or a reliable mercury oven-type thermometer at the center of the middle rack.
3. Turn the oven ON and set the temperature control knob to 400°F.
4. The amber "heat on" light will go out when the oven temperature is reached.
5. Allow three cycles for the temperature to stabilize.
6. Read the thermocouple or thermometer immediately after the light goes out for the third time, and again immediately after it comes on the next time.
7. If the average of these readings varies by more than 10°F from the dial setting, recalibrate by the following procedure. Recalibration should be attempted only by a competent service technician.

Use the following procedure to recalibrate the oven:

1. Loosen the two set screws that secure the temperature-control knob to the temperature-control shaft.
2. Remove the knob from the shaft, being careful not to rotate the knob or shaft.
3. Replace the knob on the shaft so that the indicator mark on the knob points directly at the temperature that was measured at the center of the oven.
4. Re-check the oven calibration.

## CONVERSION FROM SINGLE-PHASE TO THREE-PHASE POWER (OR VICE VERSA)

Ovens are shipped wired for either single-phase or three-phase power according to the original factory order. If the oven installation requires changing the type of power used by the oven, follow the procedure below. The following drawing shows the locations of items referred to in the procedure.

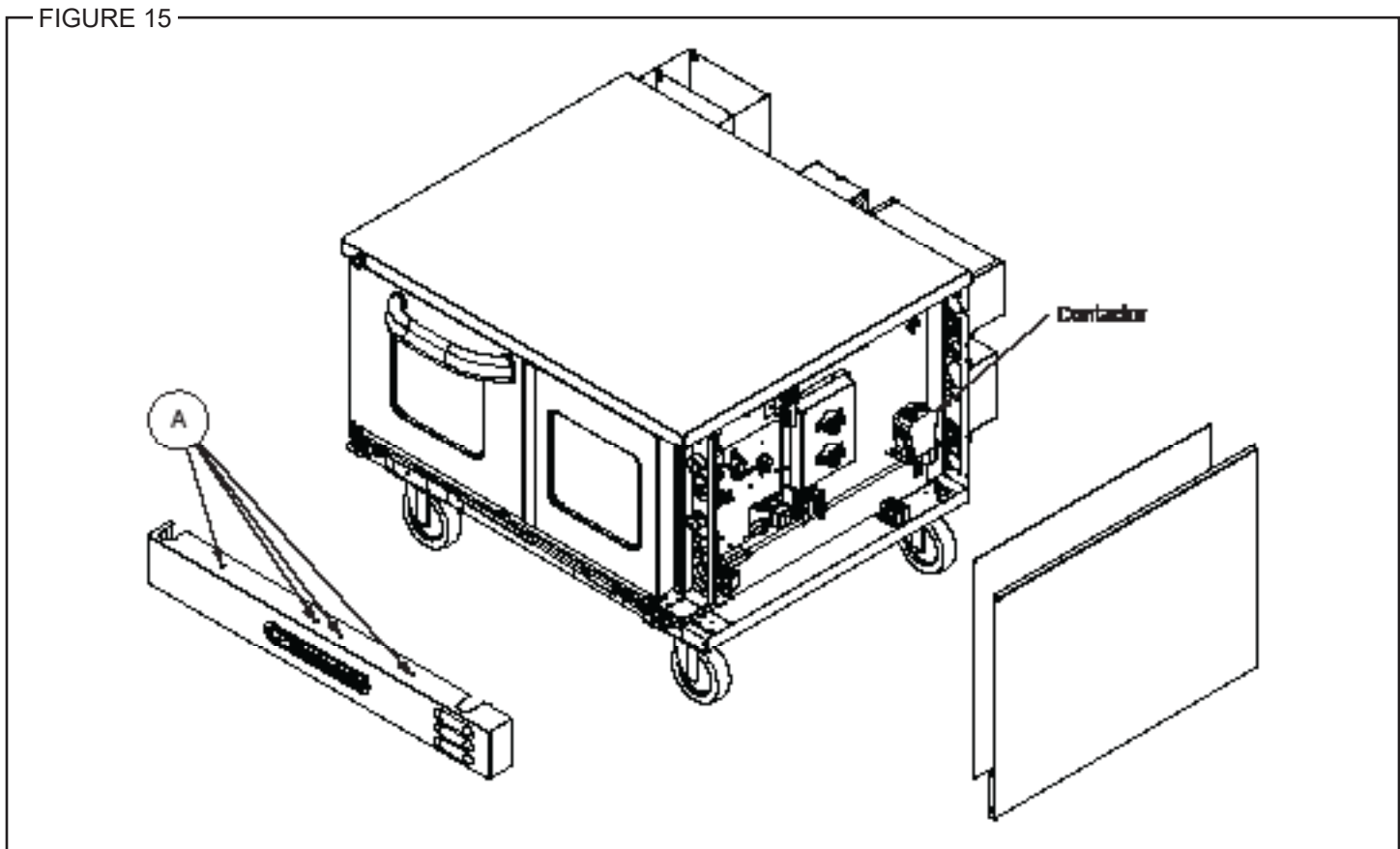

1. If the oven is connected to a power supply, **DISCONNECT OVEN FROM POWER SUPPLY.**
2. Remove the element-cover box from the back of the oven. (An oven built for three-phase power will have a small jumper wire attached with the element box cover to the back of the oven. Keep this wire.)
3. Locate and remove the four screws that secure the lower front panel (items "A" in the drawing above). Lift up the panel and pull it forward to remove it, then set it aside.
4. Locate and remove the two now-accessible screws that secure the lower front corner of the side panel.
5. Locate and remove the three screws that secure the back edge of the side panel to the oven (items "B" in the drawing above). Remove the side panel and insulation and set them aside.
6. Locate the wires running from the supply-power terminal block to the contactor. If converting from three-phase to single-phase power, remove the wire T2 (as shown in the following drawing) and go on to the next step. If converting from single-phase to three-phase power, locate the wires running from the contactor to the elements. Attached to those wires (with a wire tie) will be two wires that are not being used. Use the shorter of the two extra wires to make the additional connection (T2) shown in the following drawing. Keep the longer wire to use in the next step. (Note: If you are changing the phase-wiring of a 415V oven, refer to the corresponding wiring diagram for conversion. See page 30.)

FIGURE 16

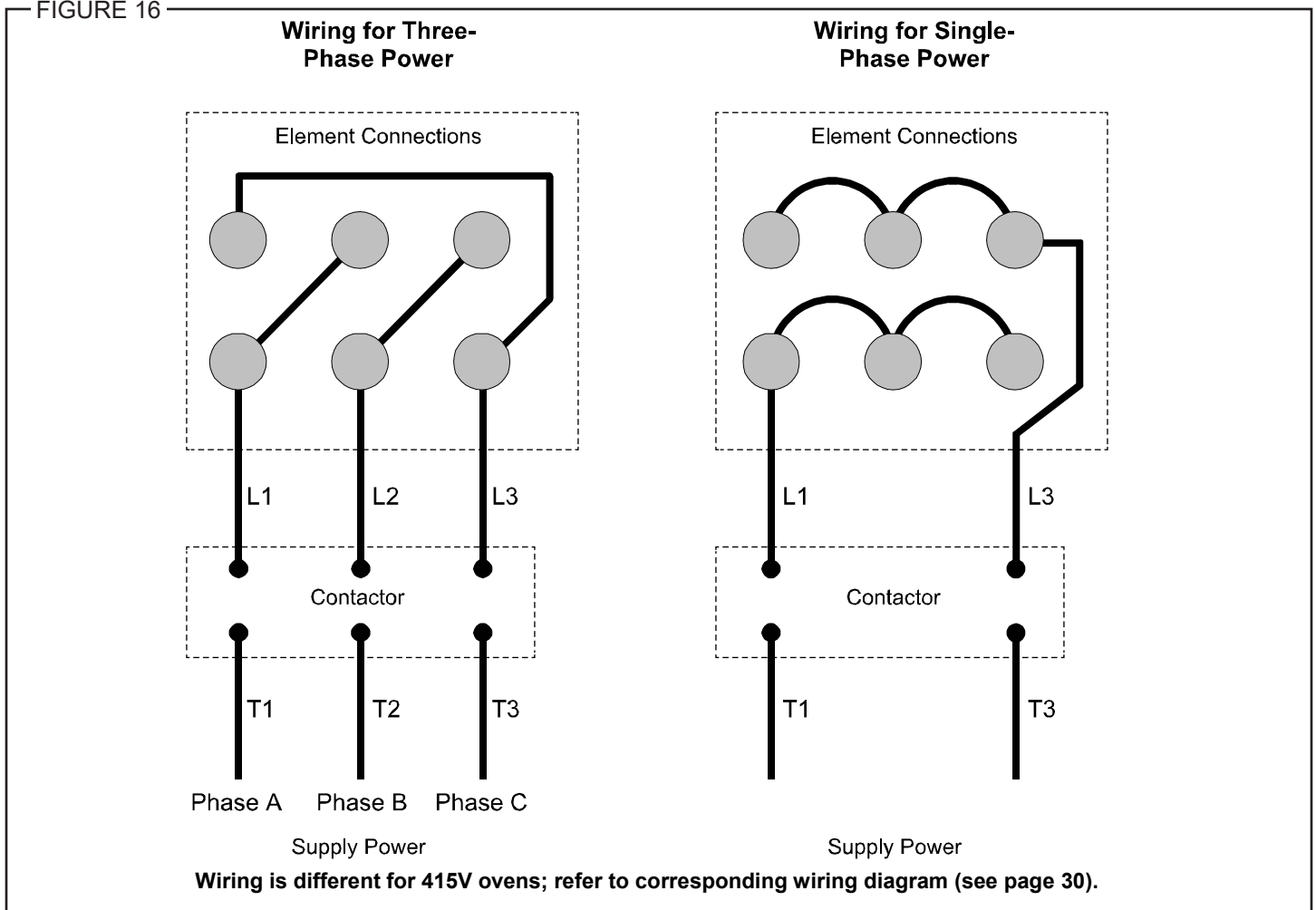

7. Locate the wires running from the contactor to the elements. If converting from three-phase to single-phase power, remove the wire L2 (as shown in the above drawing) and go on to the next step. If converting from single-phase to three-phase power, use the longer of the two extra wires found in the previous step to make the additional connection (L2) shown in the above drawing. (Again, if you are changing the phase-wiring of a 415V oven, refer to the corresponding wiring diagram for conversion. See page 30.)
8. Rewire the connections to the elements (located on the back of the oven) according to the diagram at the top of this page. If converting from three-phase to single-phase, use the wire that you saved in Step 2 to make one of the connections. (Once more, if you are changing the phase-wiring of a 415V oven, refer to the corresponding wiring diagram for conversion. See page 30.)
9. Carefully compare the new wiring connections at the elements, contactor, and supply-power terminal block to the wiring diagram for the oven. (See page 30 for the location of the wiring diagram on the oven, or page 30 for wiring diagrams printed in this manual). Verify that all connections are tight.
10. Reattach the element-cover box, right-side panel, and lower-front panel.
11. Connect the oven to the power supply according to the procedure on page 15. Note that the supply-power connections depend on whether the supply power is three-phase or single phase, and so will be different than they were prior to the conversion.
12. Double-check supply-wire sizing for new amperage load (see page 4).

# TROUBLESHOOTING

## WARNING

ADJUSTMENTS AND SERVICE WORK MAY BE PERFORMED ONLY BY A QUALIFIED TECHNICIAN WHO IS EXPERIENCED IN, AND KNOWLEDGEABLE WITH, THE OPERATION OF COMMERCIAL COOKING EQUIPMENT. HOWEVER, TO ASSURE YOUR CONFIDENCE, CONTACT YOUR AUTHORIZED SERVICE AGENCY FOR RELIABLE SERVICE, DEPENDABLE ADVICE OR OTHER ASSISTANCE, AND FOR GENUINE FACTORY PARTS.

## NOTICE

Warranty will be void and the manufacturer is relieved of all liability if service work is performed by other than a qualified technician, or if other than genuine Southbend replacement parts are installed.

When any difficulty arises it is always a good idea to check that the oven has been connected to the type of voltage for which it was manufactured. The serial plate is located on the inside of the lower front panel. It will list the type of voltage for which the unit was manufactured. In addition, a wiring diagram is attached to the side of the slide-out control panel, as well as reproduced in this manual (see page 30).

## TROUBLESHOOTING GUIDE

The left column of the following table lists symptoms that indicate a problem, while the center and right columns list the possible causes and appropriate corrective action. Note that the recommendations of this table assume that the wiring connections are good. When checking a component, always check the wiring attached to the component as well.

SYMPTOM	POSSIBLE CAUSE	CHECK OR REPLACE
Oven will not hold correct temperature.	Temperature probe not working.	Resistance across temperature probe leads at room temperature (70°F) should be approximately 1096 ohms.
	Temperature control not calling for heat.	When heat is required, there should be continuity between terminals 6 and 7 on temperature control.
	Inadequate or improper ventilation.	Check ventilation hood. Verify draw and make up air adjustment.
	Out of calibration.	Calibrate according to procedure described on page 26.
	Bad contactor.	Verify that contactor is pulling in and supplying power to the elements.
Blower motor will not come on.	No incoming electric power.	Check incoming power and fuses.
	Loose wire connections.	Check wire connections.
	Motor bad.	If power is being supplied but motor will not turn, replace motor.
	Shut down switch bad.	All power except for element supply comes through the shut down switch. Check for continuity.
	Power switch bad.	All power except for element supply comes through the power switch. Check for continuity.

## CONTROL PANEL ACCESS AND SHUT-OFF SWITCH

To access the control panel components, remove the screw at the top of the control panel and pull the top of the control panel out (see drawing below). A wiring diagram for the oven is located on the side of the control panel assembly. When the control panel is slid out, all power to the control panel is cut off by a shut down switch that is located directly behind and below the control panel. To re-energize the controls for troubleshooting, pull the white plunger on the shut down switch forward.

FIGURE 17

Accessing Control Panel Components

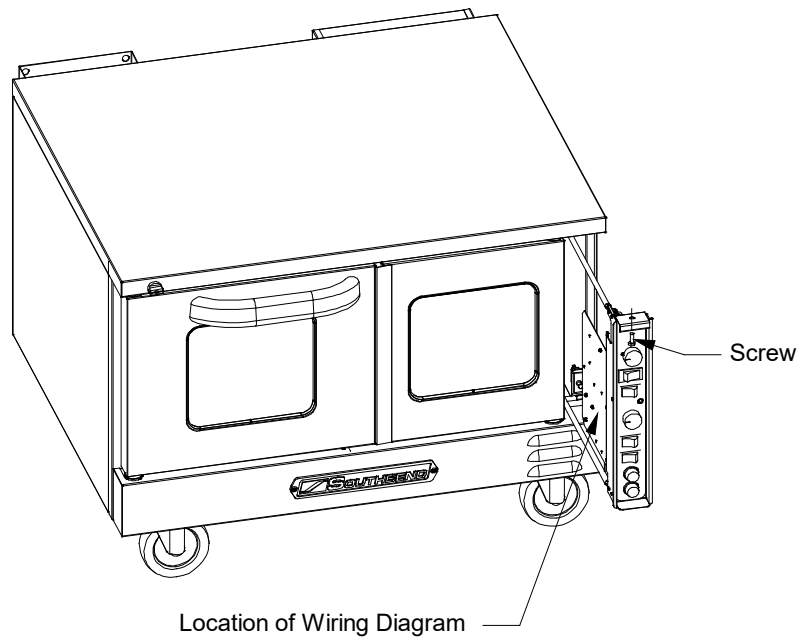

## BLOWER WHEEL REPLACEMENT

To replace the blower wheel, do the following:

1. Remove racks and rack guides.
2. Remove rear air baffle in front of blower wheel.
3. Loosen the two square heads on blower wheel hub.
4. Pull blower wheel from motor shaft. If blower wheel is difficult to pull off, use puller disk (available from Southbend as part number 1179100).

## WIRING DIAGRAMS

A wiring diagram is located on the side of the control panel assembly (as shown on page 30). Wiring diagrams also appear on the following pages of this manual. Which wiring diagram is appropriate depends on the voltage.

INDEX OF WIRING DIAGRAMS	
PAGE NUMBER	DESCRIPTION
31	208/240 Volt Models
32	380 Volt Models
33	480 Volt Models
34	415 Volt WYE Models

WIRING DIAGRAM FOR 208/240 VOLT MODELS

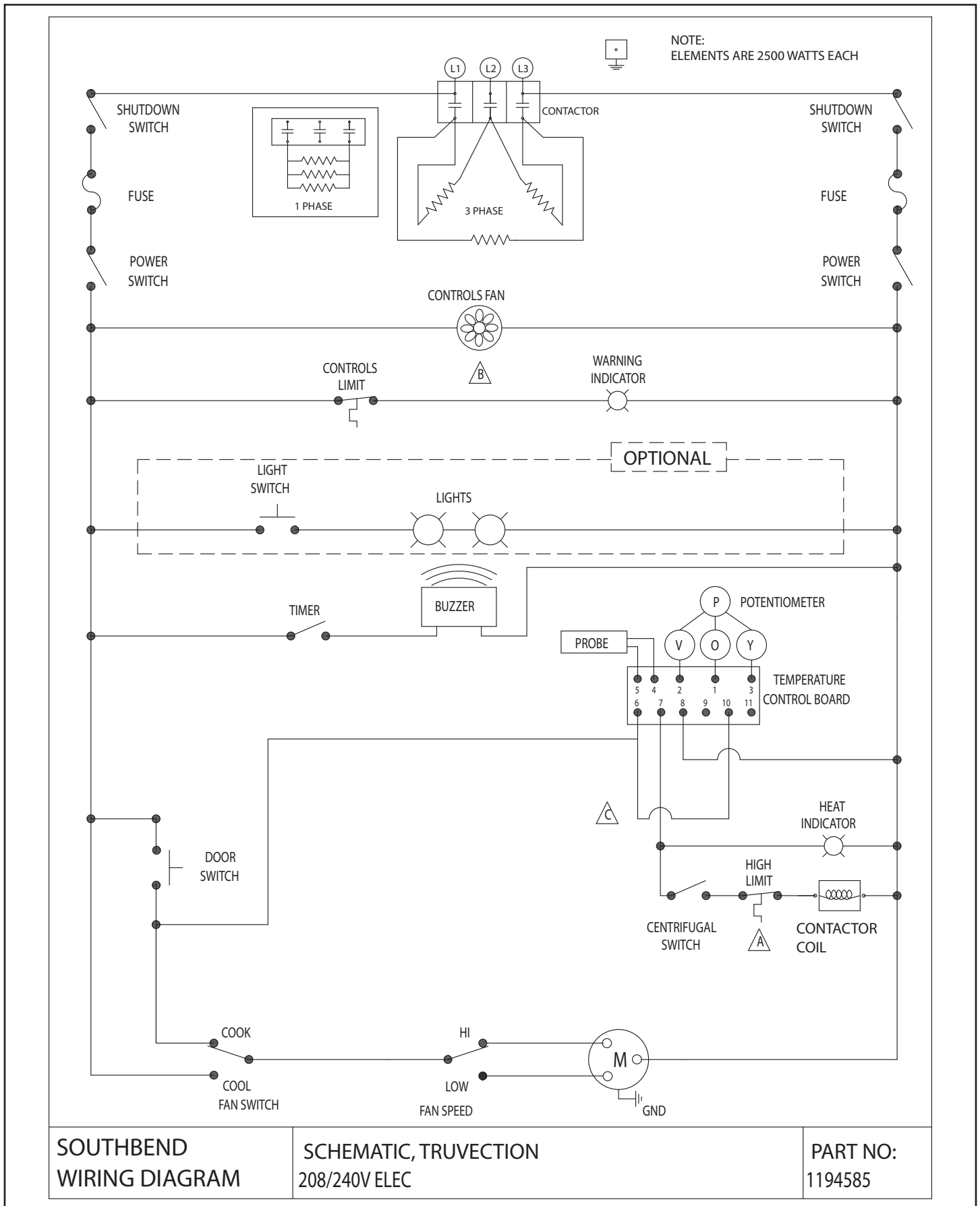

WIRING DIAGRAM FOR 380 VOLT MODELS

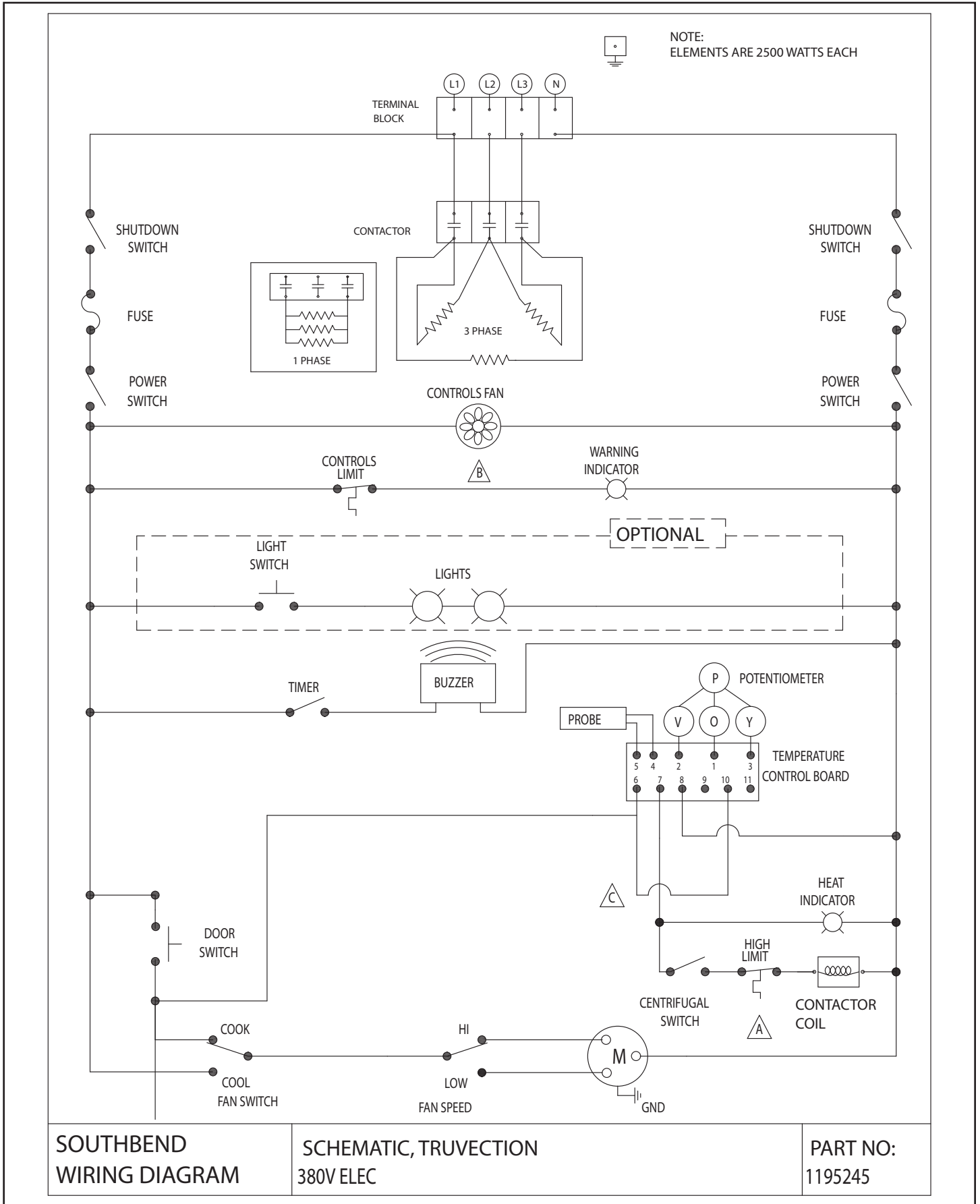

SOUTHBEND  
WIRING DIAGRAM

SCHEMATIC, TRUVECTION  
380V ELEC

PART NO:  
1195245



WIRING DIAGRAM FOR 480 VOLT MODELS

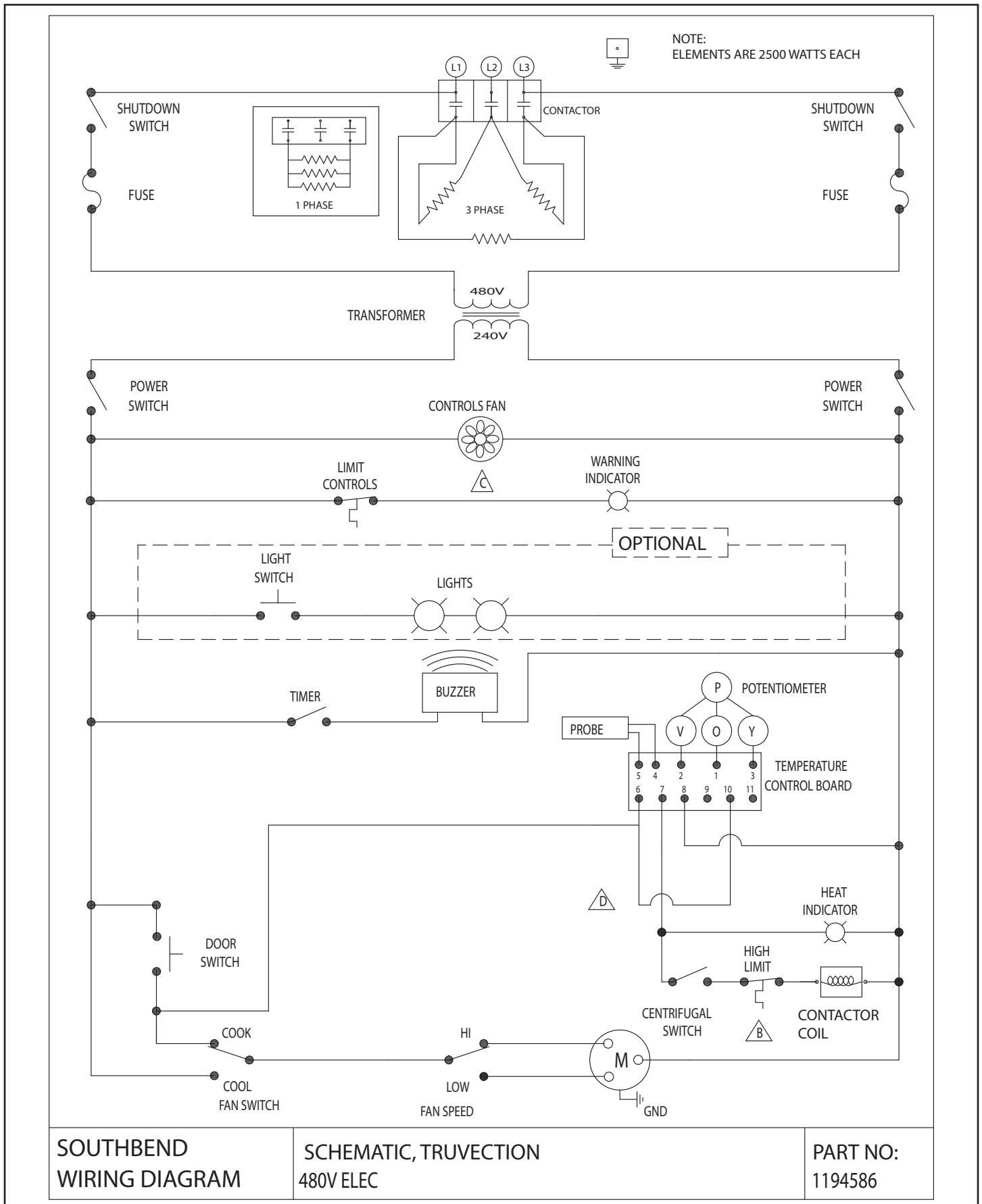

SOUTHBEND  
WIRING DIAGRAM

SCHEMATIC, TRUVECTION  
480V ELEC

PART NO:  
1194586

WIRING DIAGRAM FOR 415 VOLT WYE MODELS

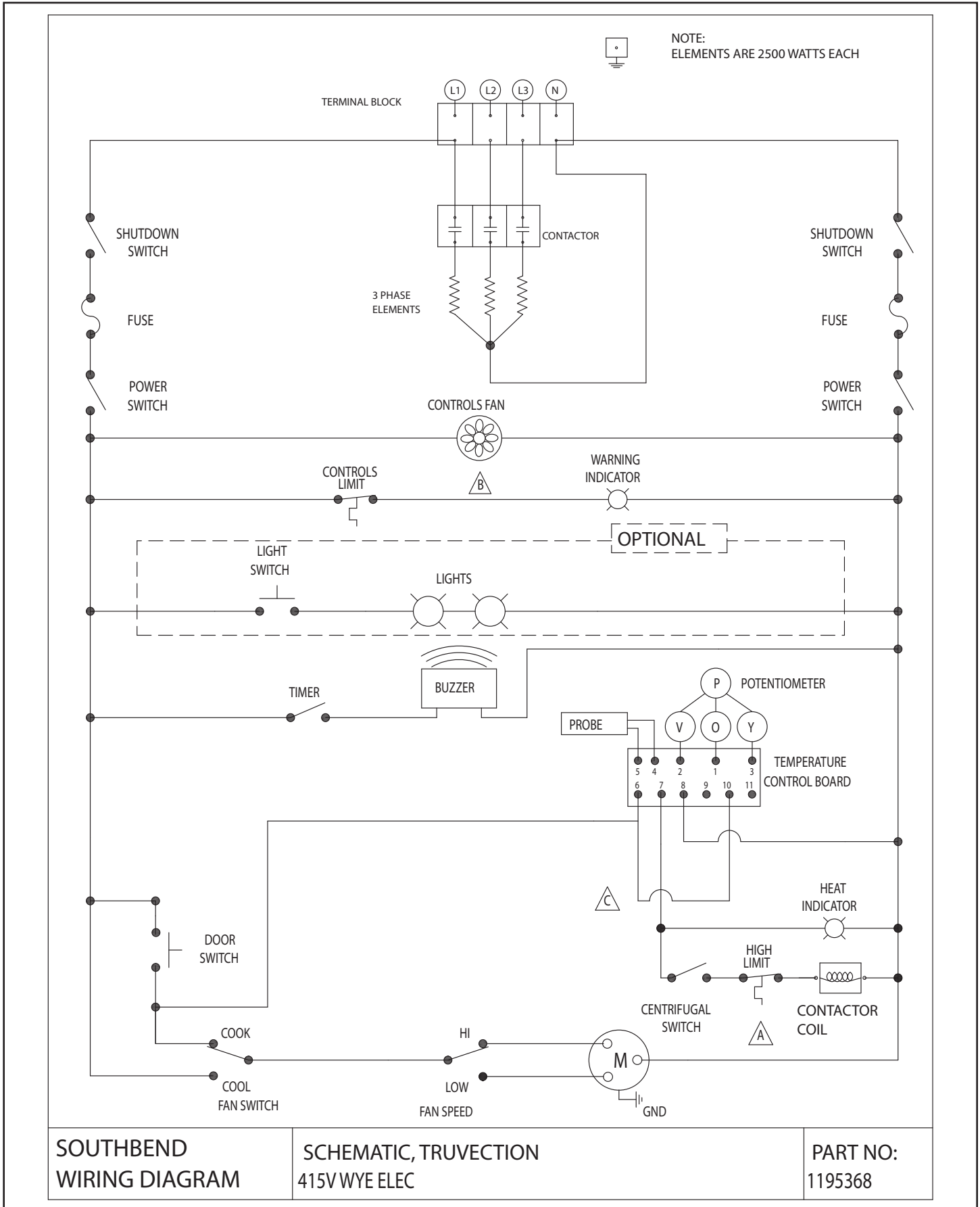

SOUTHBEND  
WIRING DIAGRAM

SCHEMATIC, TRUVECTION  
415V WYE ELEC

PART NO:  
1195368

# NOTES

# TVES/10SC, TVES/20SC & TVES/30SC TruVection Electric Convection Ovens



A product with the Southbend name incorporates the best in durability and low maintenance. We all recognize, however, that replacement parts and occasional professional service may be necessary to extend the useful life of this appliance. When service is needed, contact a Southbend Authorized Service Agency, or your dealer. To avoid confusion, always refer to the model number, serial number, and type of your appliance.



## SOUTHBEND

 **MIDDLEBY** A Middleby Company

1100 Old Honeycutt Road Fuquay-Varina, North Carolina 27526 USA  
[www.southbendnc.com](http://www.southbendnc.com)