



IMPORTANT FOR FUTURE REFERENCE

Please complete this information and retain this manual for the life of the equipment:

Model #: _____

Serial #: _____

Date Purchased: _____

PARTS LIST
Electric Modular Skillets
EMTS-30 EMTS-40 EMTS-60

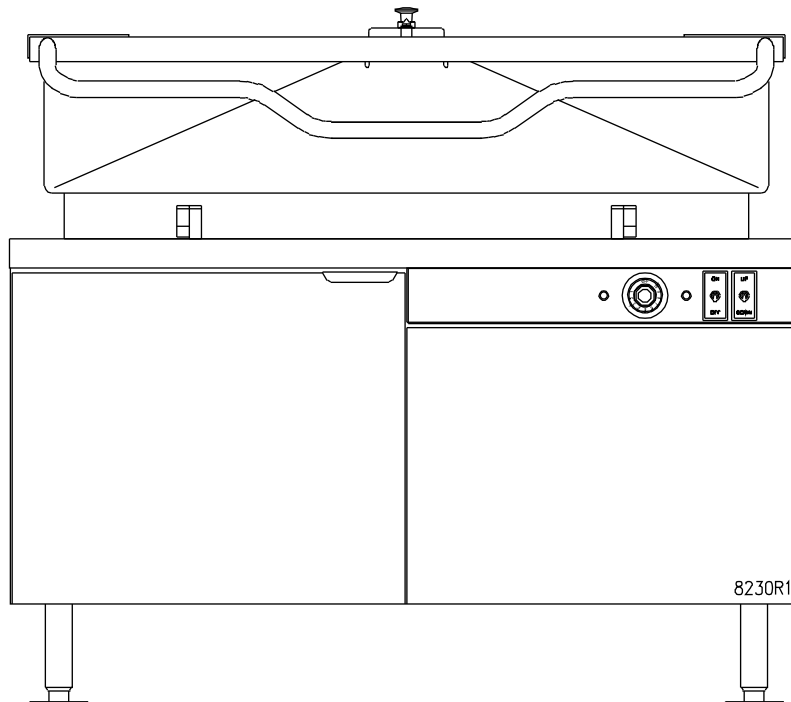

WARNING

Improper installation, adjustment, alteration, service or maintenance can cause property damage, injury or death. Read the installation, operating and maintenance instructions thoroughly before installing or servicing this equipment.

CROWN FOOD SERVICE EQUIPMENT

 A Middleby Company

70 Oakdale Road, Downsview (Toronto) Ontario, Canada, M3N 1V9

Telephone: 919-762-1000 www.crownsteamgroup.com

Printed in Canada



PARTS LIST, ELECTRIC MODULAR SKILLET, MODELS: EMTS-30, EMTS-40, EMTS-60

FIGURE 1

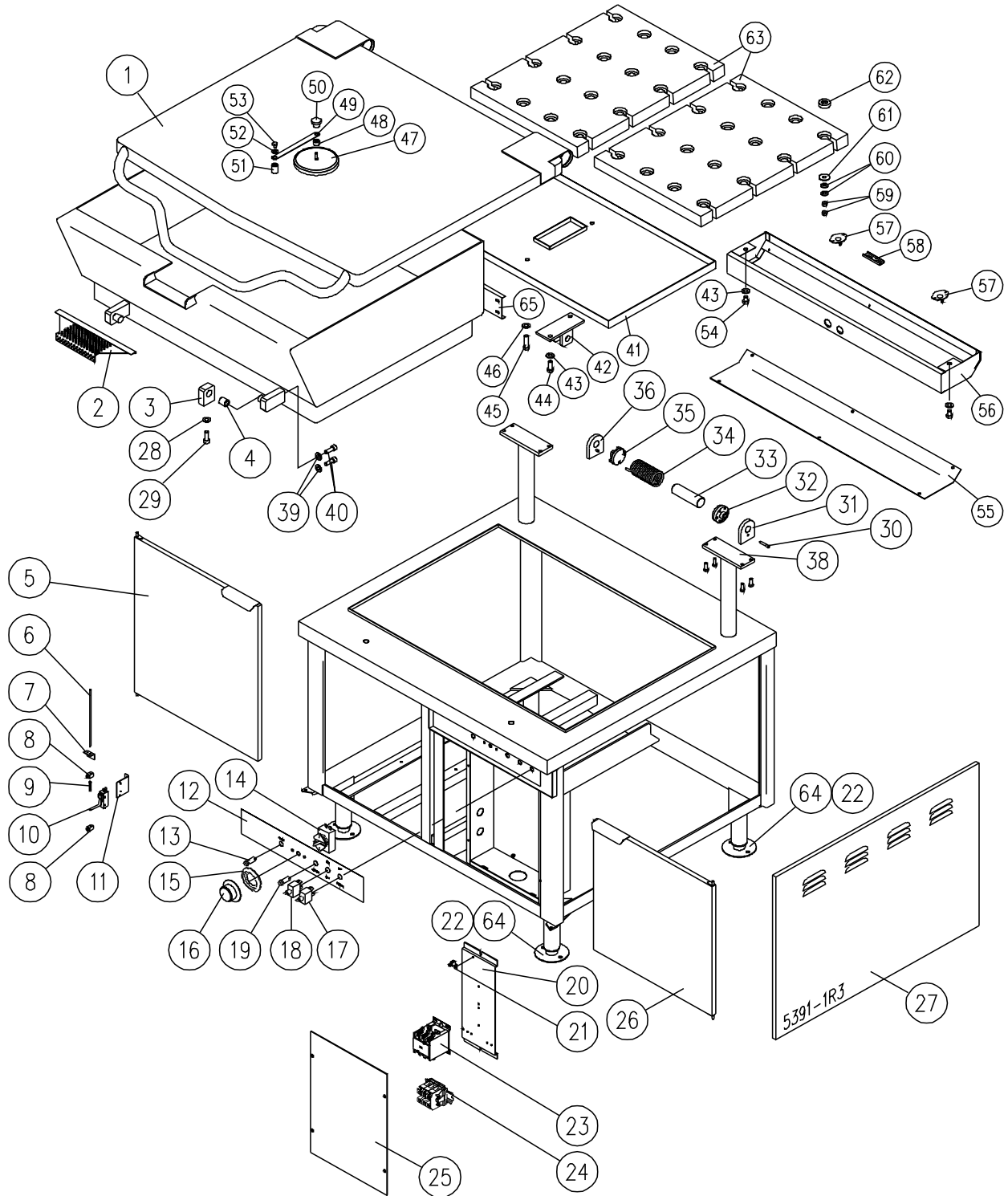

PARTS LIST, ELECTRIC MODULAR SKILLETS, MODELS: EMTS-30, EMTS-40, EMTS-60

FIGURE 1

<u>ITEM</u>	<u>PART NO.</u>	<u>DESCRIPTION</u>	<u>QUANTITY</u>		
			<u>30</u>	<u>40</u>	<u>60</u>
**	1.	8113-4	1		
		8114-4		1	
		8115-4			1
	2.	7380-1	1	1	1
	3.	5877-1	2	2	2
	4.	3704-1	2	2	2
**	5.	3209-1	1		
		3596-1		1	1
*		5-MC02	2	2	2
	6.	9-3443	1	1	1
	7.	9-3444	1	1	1
	8.	9-3345	2	2	2
	9.	9-3446	1	1	1
	10.	4065-2	1	1	1
	11.	3838-1	1	1	1
**	12.	3040-1	1		
		3040-2		1	1
	13.	4-PL07-1	1	1	1
	14.	4-TH47	1	1	1
	15.	4-TB05	1	1	1
**	16.	4-TK05	1	1	1
		4737-1	1	1	1
		4736-1	1	1	1
	17.	9110-1	1	1	1

PARTS LIST, ELECTRIC MODULAR SKILLETTS, MODELS: EMTS-30, EMTS-40, EMTS-60

<u>ITEM</u>	<u>PART NO.</u>	<u>DESCRIPTION</u>	<u>QUANTITY</u>			
			<u>30</u>	<u>40</u>	<u>60</u>	
18.	9111-1	Up/Down Switch	1	1	1	
19.	4-PL06-1	Pilot Light - Amber	1	1	1	
20.	8068-1	Panel Sub Assembly	1	1	1	
21.	4-70EU	Ground Lug	1	1	1	
22.	9029-5	Hex Nut	4	2	2	
**	23.	4-CG42-1	Contactor, 208-240V, 4-Pole	1	1	1
		9348-208	Contactor, 240/380/415/480V	1	1	1
**	24.	6161-3	Modular Terminal Assembly, 3 Pole, (380, 415, 480V)	1	1	1
		Includes the following parts:				
		9374-1	Modular Terminal, Grey	3	3	3
		9375-1	End Plate	1	1	1
		9369-1	End Clamp	2	2	2
		9368-079	Mounting Rail, 79 mm	1	1	1
		6161-4	Modular Terminal Assembly, 4 Pole (208-240V)	1	1	1
		Includes the following parts:				
		9374-1	Modular Terminal, Grey	4	4	4
		9375-1	End Plate	1	1	1
		9369-1	End Clamp	2	2	2
		9368-098	Mounting Rail, 98 mm	1	1	1
		6161-4N	Modular Terminal Assembly, 3 Pole with Neutral, (220/380, 240/415V)	1	1	1
		Includes the following parts:				
		9374-1	Modular Terminal, Grey	3	3	3
		9374-2	Modular Terminal, Blue	1	1	1

PARTS LIST, ELECTRIC MODULAR SKILLETS, MODELS: EMTS-30, EMTS-40, EMTS-60

<u>ITEM</u>	<u>PART NO.</u>	<u>DESCRIPTION</u>	<u>QUANTITY</u>			
			<u>30</u>	<u>40</u>	<u>60</u>	
	9375-1	End Plate	1	1	1	
	9369-1	End Clamp	2	2	2	
	9368-098	Mounting Rail, 98 mm	1	1	1	
25.	3684-1	Component Box Cover	1	1	1	
**	26.	3571-1	Right Door	1	1	1
	3597-1	Right Hand Door		1	1	
27.	3201-1	Side Panel	2	2	2	
28.	S01X-12	Split Lock Washer, 1/2	2	2	2	
29.	M68P-1213-1	Socket Hd Screw, 1/2-13 UNC x 1 Lg.	2	2	2	
30.	8-2029	Lock Pin	2	2	2	
31.	8-2035L	End Lock Plate	2	2	2	
32.	5428-1	Stationary Disc	2	2	2	
33.	5430-1	Core	2	2	2	
34.	8-2026	Spring	2	2	2	
35.	5429-1	Rotary Disc	2	2	2	
36.	8-2021	End Stop Plate	2	2	2	
37.	M50S-1420-34	Hex Head Cap Screw, 1/4 - 20 x 3/4	8	8	8	
**	38.	5651-1	Hinge Support Assembly	2	2	
	5652-2	Hinge Support Assembly			2	
39.	S01X-38	Split Lock Washer, 3/8	4	4	4	
40.	M68P-3816-1	Socket Hd. Screw, 3/8-16 UNC x 1 Lg.	4	4	4	
41.	8066-1	Element Cover	1			
	8067-1	Element Cover		1	1	
42.	8062-1	Yoke Assembly	1			

PARTS LIST, ELECTRIC MODULAR SKILLETS, MODELS: EMTS-30, EMTS-40, EMTS-60

<u>ITEM</u>	<u>PART NO.</u>	<u>DESCRIPTION</u>	<u>QUANTITY</u>		
			<u>30</u>	<u>40</u>	<u>60</u>
	8062-2	Yoke Assembly		1	1
43.	S05N-38	Split Lock Washer, 3/8	4	4	4
44.	M50S-3816-1	Hex Hd. Screw, 3/8 -16 UNC x 1 Lg.	2	2	2
45.	M50S-3816-112	Hex Hd. Screw, 3/8-16 UNC x 1-1/2 Lg.	6	4	4
46.	F05N-38	Flat Washer, 3/8	6	4	4
47.	4139-1	Vent Cover	1	1	1
48.	4355-1	Swivel Spacer	1	1	1
49.	5817-1	Arm	1	1	1
50.	9248-1	Knob	1	1	1
51.	5836-1	Swivel Base	1	1	1
52.	F05N-14	Washer, Stainless Steel, 1/4"	1	1	1
53.	9031-5	Hex Screw, 1/4 - 20 x 3/8 S.S.	1	1	1
54.	M50S-3816-12	Hex Hd. Screw, 3/8-16 UNC x 1/2 Lg.	2	2	2
55.	8061-1	Terminal Enclosure Cover	1		
	8061-2	Terminal Enclosure Cover		1	1
56.	8054-1	Terminal Enclosure Box	1		
	8054-2	Terminal Enclosure Box		1	1
57.	4874-1	High Limit Thermostat	2	3	3
58.	5952-1	Clamp	1	1	1
59.	1-69C0	Hex Nut, 5/16-18 UNC	64	80	80
60.	9063-1	Disc Springs	64	80	80
61.	9078-1	Flat Washer, 11/32 ID x 1-1/2 OD x 0.083 Thick	32	40	40
62.	3599-1	Element Block Spacer	32	40	40
63.	7545-208	Element Assembly, 208V, 6 kW	2		

PARTS LIST, ELECTRIC MODULAR SKILLETS, MODELS: EMTS-30, EMTS-40, EMTS-60

<u>ITEM</u>	<u>PART NO.</u>	<u>DESCRIPTION</u>	<u>QUANTITY</u>			
			<u>30</u>	<u>40</u>	<u>60</u>	
	7545-220	Element Assembly, 220/380, 6 kW	2			
	7545-240	Element Assembly, 240/415V, 6 kW	2			
	7545-277	Element Assembly, 480 (277V), 6 kW	2			
	7545-347	Element Assembly, 600/347V, 6 kW	2			
	7547-208	Element Assembly, 208V, 6 kW		3	3	
	7547-220	Element Assembly, 220/380, 6 kW		3	3	
	7547-240	Element Assembly, 240/415V, 6 kW		3	3	
	7547-277	Element Assembly, 480 (277V), 6 kW		3	3	
	7547-347	Element Assembly, 600/347V, 6 kW	4	4	4	
64.	5379-1	Adjustable Flanged Leg	4	4	4	
65.	8073-1	Rear Skirt Cover	1			
	8073-2	Rear Skirt Cover		1	1	
* **	66.	9092-3	Glass Fuse, 3A, 250V (380/220V & 415/240V)	1	1	1
		9001-2	Fuse, 1/2A, 600V (380-600V)	2	2	2
* **	67.	9068-1	Fuse Holder (208, 220, 240V)	2	2	2
		9068-1	Fuse Holder (380/220V & 415/240V)	1	1	1
		9002-1	Fuse Holder (380-600V)	2	2	2

* NOT SHOWN.

** SELECT AS REQUIRED.

PARTS LIST, ELECTRIC MODULAR SKILLET, MODELS: EMTS-30, EMTS-40, EMTS-60

FIGURE 2

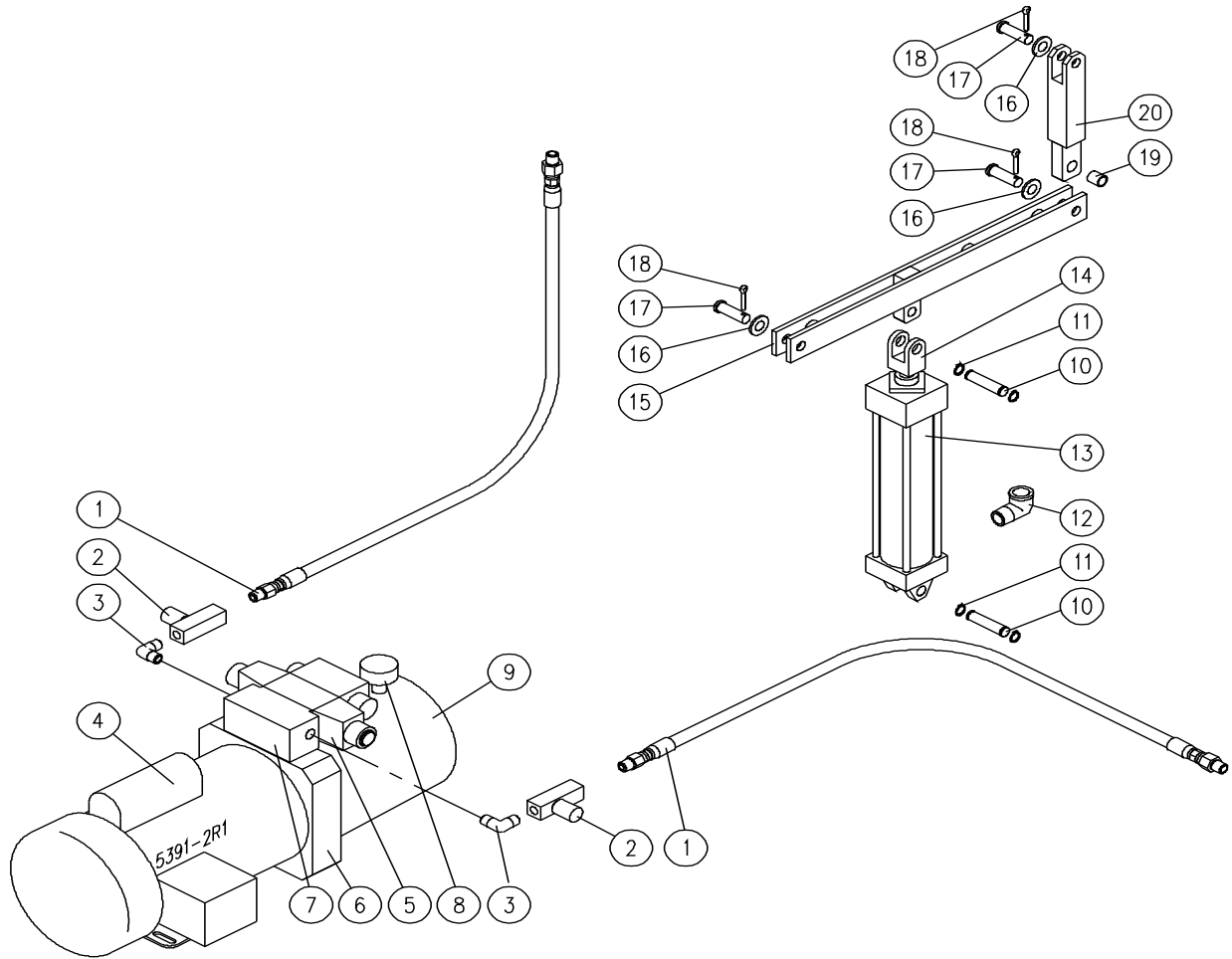

PARTS LIST, ELECTRIC MODULAR SKILLETTS, MODELS: EMTS-30, EMTS-40, EMTS-60

FIGURE 2

<u>ITEM</u>	<u>PART NUMBER</u>	<u>DESCRIPTION</u>	<u>QUANTITY</u>	
	1.	4511-1	Hose Assembly	2
*	1A.	9420-1	Straight Fitting MORB-FP	2
	2.	9418-1	Flow Control	2
	3.	9419-1	Elbow	2
*	3A.	9421-1	Straight Fitting MORB-FJS	2
**	4.	9414-1	Motor, 115/208/230V, 60 Hz	1
		9414-2	Motor, 230/460V, 60 Hz	1
		9414-3	Motor , 575V, 60 Hz	1
*		4515-1	Fan Blade	1
**	5.	9119-1	Directional Valve, 110/120 VAC, 50/60 Hz	1
		9119-2	Directional Valve, 220/240 VAC, 50/60 Hz	1
* **		9118-1	Coil, 110/120 VAC, 50/60 Hz	2
		9118-2	Coil, 220/240 VAC, 50/60 Hz	2
	6.	9-3032	Pump complete with Integral Relief Valve	1
	7.	9417-1	Manifold	1
	8.	9416-1	Breather	1
	9.	9415-1	Tank, 1 Gallon	1
	10.	4062-1	Pin complete with Retaining Rings	2
	11.	1-R350	Retaining Ring, External	4
	12.	4109-1	Street Elbow	2
	13.	4112-1	Cylinder	1
*		9-3318	Cylinder Kit	
	14.	9-3035	Rod Clevis	1
	15.	7849-1	Main Lift Arm	1

PARTS LIST, ELECTRIC MODULAR SKILLETTS, MODELS: EMTS-30, EMTS-40, EMTS-60

<u>ITEM</u>	<u>PART NUMBER</u>	<u>DESCRIPTION</u>	<u>QUANTITY</u>
16.	F01X-12	Flat Washer Series "R" \varnothing 1/2	3
17.	9-3039	Clevis Pin	3
18.	5329-4	Cotter Pin, \varnothing 1/8 x 1 Lg.	3
19.	9263-0810	Self Lubricating Bushing	1
20.	2567-1	Link Arm	1
*	21.	Flame Retardant Hydraulic Oil AWM 32 or Equivalent 4.54 L	

* NOT SHOWN.

** SELECT AS REQUIRED.