



AMERICAN EAGLE[®]
FOOD MACHINERY, INC.

AE-10DCA
10 Quart Countertop
Planetary Mixer

773.376.0800 (P) • 773.376.2010 (F) • 3131 S. Canal St. Chicago, IL 60616

Lower Your Total Cost Of Ownership With American Eagle® Mixers! All-Inclusive Accessories, Competitive Pricing, And Reliability Make Us The Value Leader In The Industry.

Quality Design

- Powerful 7/8 HP Motor
- 100% Gear-Driven Transmission, Precision Milled, Heat Treated Steel Alloy Gears And Shafts
- Heavy Duty, Cast Iron and Steel Construction
- NSF Approved Heat Treated Enamel Paint Resists Rust, Scratches, And Dents
- Thermal Overload Protection With Reset
- Non-Skid Rubber Base
- ETL Certified To Conform To: NSF No. 8, CSA, CE Standards
- Heavy Duty, 6 Foot Hard Wired Power Cable And Plug



Standard Features

- Digital Control Panel with 30 Minute Timer
- 15 Fixed Speeds
- Safety Guard with Auto-Shutoff and Intergrated Ingredient Chute
- 1 Year Limited Warranty*

Standard Accessories

- High Polish 10 Quart Stainless Steel Bowl
- Aluminum Dough Hook
- Stainless Steel Wire Whip
- Aluminum Beater



Other Available Sizes

- AE-20GA 20 Quart Planetary Mixer
- AE-30GA 30 Quart Planetary Mixer
- AE-40PA 40 Quart Planetary Mixer
- AE-60N4A 60 Quart Planetary Mixer
- AE-80N4A 80 Quart Planetary Mixer (Special Order Only)

Proud Member of:

 North American Association of
 Food Equipment Manufacturers

Quality • Value • Reliability



AMERICAN EAGLE[®]
FOOD MACHINERY, INC.

AE-10DCA
10 Quart Countertop
Planetary Mixer

sales@ameagle.biz • www.americaneaglemachine.com

Machine Specifications

Model	Capacity**	Motor	Voltage V/HZ/PH	Transmission	Total Speed Options**	Safety Guard	Power Bowl Lift	Timer
AE-10DCA	10 Quart Bowl Max 5 lbs Dough	7/8 HP	115/60/1	Gear Driven	15	Yes	No	30 Min

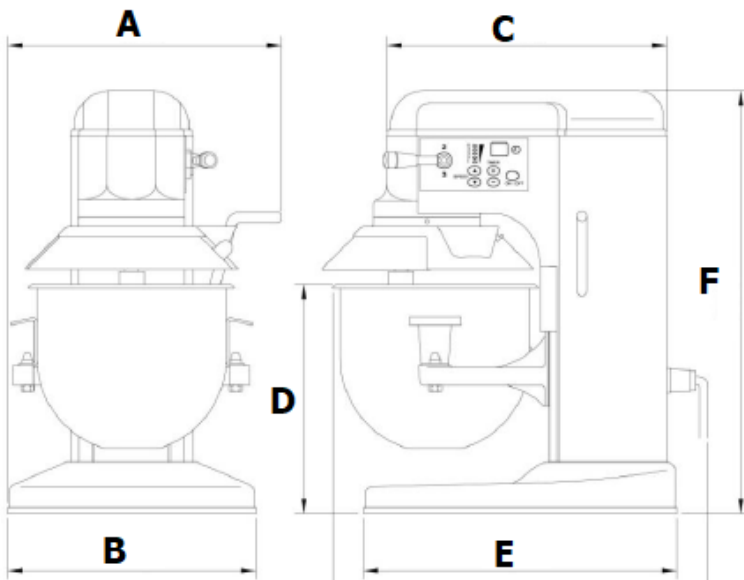

Measurements

Dimension	Inches	Centimeters
A	13.4	34
B	11.8	30
C	13.4	34
D	12	30.5
E	15	38
F	21.5	54.5

RPM Speeds		DC Motor Speed Control Setting				
		1	2	3	4	5
Gear Shifter Setting***	1	193	296	354	438	496
	2	206	315	378	468	529
	3	249	381	456	564	638

Dimensions and Shipping Information

Model	Overall Dimensions	Foot Print	Net Weight	Shipping Dimensions	Ship Weight
AE-10DCA	13.1" L x 17.7" W x 21.2" H	11.8"L x 15"W	52 lbs.	21"W x 17"L x 25"H	72 lbs.

*Warranty must be registered. Use of high speed with dough will void warranty, changing speeds improperly will void warranty

**Capacity may be diminished depending on dough density and absorption ratio. Capacity listed is assuming a 60% absorption ratio.

***To change gear speeds, first turn off the machine. Move the lever into position so that the gears lock, then resume mixing.

Proud Member of:



Quality • Value • Reliability