



# BEVERAGE-AIR

Project: _____	AIA#
Item: _____	
Location: _____	SIS#
Approved: _____	

**HBR27HC BOTTOM MOUNT REACH-IN REFRIGERATOR**

## HORIZON BOTTOM MOUNT REACH-IN HBR27HC Half-Solid Door Reach-In Refrigerator Hydrocarbon Series

**MODEL:  
HBR27HC-1-HS**



**7 Year Parts/Labor Warranty  
7 Year Compressor Warranty**

### CABINET CONSTRUCTION

- Stainless steel front, side, and grille (galvanized back & bottom)
- Stainless steel interior
- LED lighting
- Full electronic control with one-touch defrost
- One-piece grille allow easy removal/installation for preventative maintenance
- Door lock (solid doors only)
- Self closing door with 120° stay open feature
- Spring-loaded style hinges
- Plug-in magnetic door gaskets
- Three (3) heavy duty epoxy coated wire shelves
- 6" Casters with two (2) brakes

### OPTIONS & ACCESSORIES

- Stainless steel universal tray slide pair, 1 tray slide set for (1) 18" x 26" or (2) 14" x 18" pans (AC)
- Wine models
- 3" Casters or 6" legs
- Epoxy shelves
- Shelf clips
- Remote option\* (see note on back page)

### REFRIGERATION SYSTEM

- Uses environmentally friendly, energy efficient R290 refrigerant, and meets all regulatory requirements for CARB, SNAP, DOE & more
- Hot gas condensate evaporator
- Adaptive defrost
- Epoxy coated evaporator coil
- Maintains product temperatures between 36°F and 38°F



  
Please verify qualifying units by visiting:  
[www.energystar.gov/cfs](http://www.energystar.gov/cfs)

3779 Champion Blvd., Winston-Salem, NC 27105  
1-888-845-9800 Fax: 1-336-245-6453  
[Beverage-Air.com](http://Beverage-Air.com) [Sales@bevair.com](mailto:Sales@bevair.com)



# BEVERAGE-AIR®

MODEL	HBR27HC-1-HS
<b>EXTERNAL DIMENSIONAL DATA</b>	
Width Overall	30"
Depth Overall with Handle	33 ¾"
Height Overall	84 ⅛"
Number of Doors	2
Depth with Door Open 90°	60"
Door Openings (in)	26 ⅞" x 24 ¾"
<b>INTERNAL DIMENSIONAL DATA</b>	
NET Capacity (cubic ft.)	25.97
Internal Width Overall (in)	27"
Internal Depth Overall (in)	28 ½"
Internal Height Overall (in)	61 ¾"
Internal Height Useable (in)	55"
Number of Shelves	3
<b>ELECTRICAL DATA</b>	
Full Load Amperes 115/60/1	2.88
<b>REFRIGERATION DATA</b>	
Horsepower	1/4
Capacity (BTU/Hr)	1702
Heat Rejection (BTU/Hr)	2553
Charge (lbs/grams/ounces)	0.1985 / 90 / 3.18
<b>SHIPPING DATA</b>	
Gross Weight - Crated	420 lbs
Height - Crated	88"
Width - Crated	33"
Depth - Crated	37"

\*NOTE: Remote units are field wired and come with 6" legs. Refrigerant must be specified at time of order.

We reserve the right to change specifications and product design without notice. Such revisions do not entitle the buyer to corresponding changes, improvements, additions or replacements for previously purchased equipment. Dimensional tolerances +/- 1/4". Metric dimensions (MM).

## Bottom Mount Reach-In Refrigerator Model: HBR27HC-1-HS

### Model Views

Required Clearance: Bottom & Rear 3"

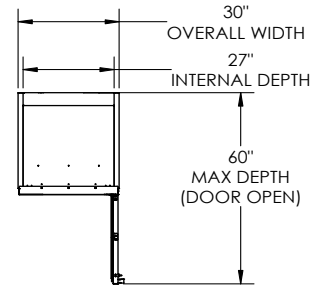

### PLAN VIEW

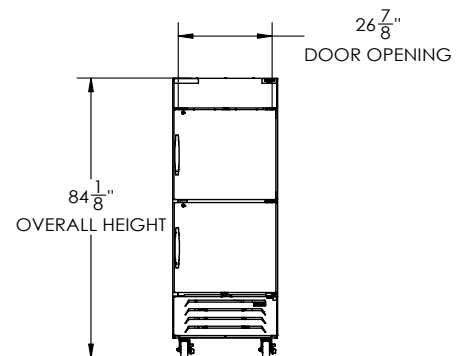

### ELEVATION VIEW

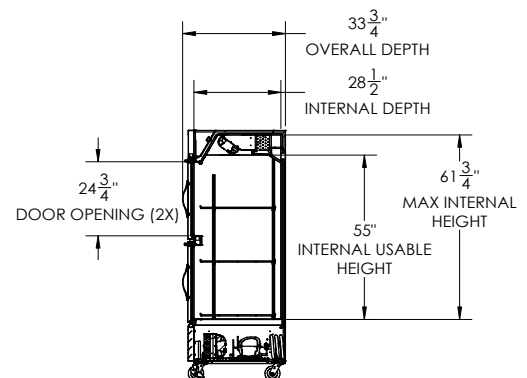

### SIDE VIEW

### ELECTRICAL CONNECTION



115/60/1  
NEMA 5-15P

Unit pre-wired at factory and include 8' long cord and plug set.

