

MADE IN ITALY



## 5010 NFN

### Standard Features

- 1 Swinging Auto-Closing Door
- Insulated on Three Sides
- Stainless Steel Construction
- Capacity for (48) 1/3 Pans or (26) 1/2 Pans
- Silver
- Accessories included:
  - 7 Wire Shelves
  - 4 Casters
  - 2 Front Levelers



1-year parts and labor warranty, 3-year warranty for the compressor (US Only)

# REACH IN FREEZER

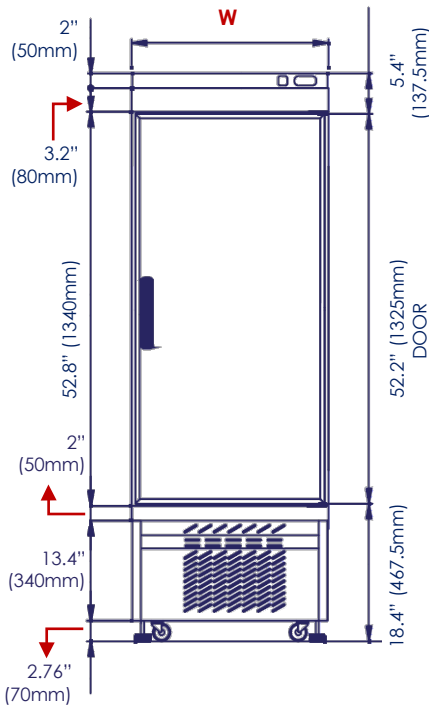

**FRONT VIEW**

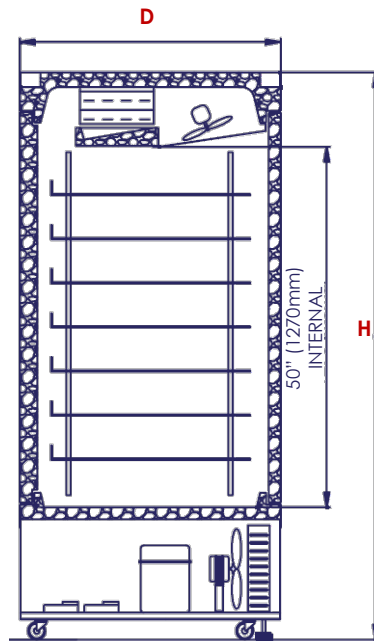

**SIDE VIEW**

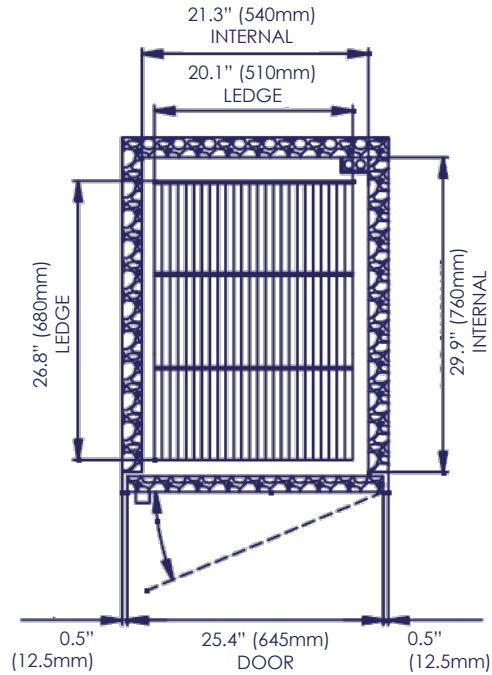

**TOP VIEW**

SPECIFICATIONS	
5010 NFN	
<b>Capacity</b>	24 Cubic Feet (0.68 Cubic Meters)
	(48) Third Size Gelato/Steam Pans 4" Deep or (8) Full Size Sheet Pans
<b>Operating Temperature</b>	41°F / -13°F (5°C / -25°C)
<b>Refrigerant</b>	R404A
<b>Compressor Power (Hp)</b>	3/4
<b>Power Supply</b>	110V/60Hz/1ph
<b>Amps</b>	10
<b>Plug / Connection</b>	NEMA 5-15P
<b>Product Weight</b>	330 lbs (150 Kg)
<b>Product Dim. (WxDxH)</b>	26 3/8" x 35" x 76" (67 x 89 x 193 cm)
<b>Shipping Weight (lbs)</b>	373
<b>Shipping Dim. (WxDxH)</b>	31" x 39" x 84"
<b>Accessories Included</b>	(7) Shelves, (4) Casters & (2) Levelers



**Notes:**

- Properly clean and dry after daily use to ensure best performance and equipment longevity.



Nema 5-15 125 VAC  
2 Pole, 3 Wire  
Grounding

\*AMPTO is continuously improving products. Specifications are subject to change without notice.\*