

Item # _____
 Qty # _____
 Model # _____
 Project # _____



DUKERS
 Quality Commercial Refrigeration



GRIDDLE DCGMA60



Oil Tray



PRODUCT DESCRIPTION

- Stainless steel exterior and interior.
- 30,000 BTU Burners per 12" section with standby pilots.
- Independent manual controls every 12".
- Heavy duty 1" thick polished steel griddle plate.
- Each griddle is shipped with Standard Natural Gas, LP conversion kit.
- Adjustable, stainless steel legs standard.
- Full length seamless drip pan, easy to remove and clean.



HIGH QUALITY STAINLESS STEEL & ROBUST DESIGN

* All measures are presented in Inches

GRIDDLE MODEL	DIMENSION		
	Width	Depth	Height
DCGMA60	60 in	33 1/2 in	15 1/4 in



Los Angeles | San Francisco | Dallas
 Houston | Florida | Chicago | New Jersey

1-800-931-8628

@ info@dukersusa.com

www.DukersUSA.com

DETAILS & SPECIFICATIONS

GRIDDLE DCGMA60

Front View

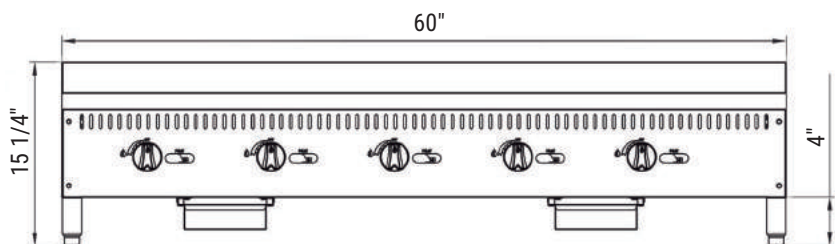

DCGMA60

GAS SOURCE	NG/Propane
WORK AREA	59.8" x 24"
BURNER	5 count
SINGLE BURNER	30000 BTU/H
COMBINED	150000 BTU/H
GAS PRESSURE	NG: 4 "WC Propane: 10 "WC
NOZZLE	NG: 37# Propane: 51#

Top View

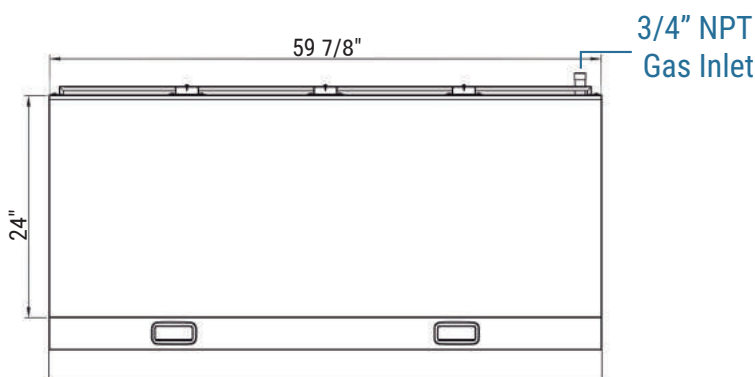

Side View

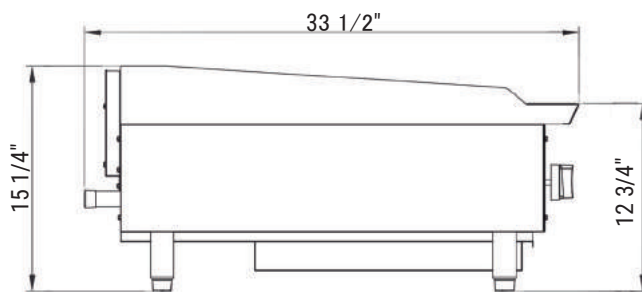

Model	Packaging Dimensions (inches)			Net Weight (lbs)	Ship Weight (lbs)
	W	D	H		
DCGMA60	62 1/4"	36 1/4"	18 7/8"	716	772



Los Angeles | San Francisco | Dallas
Houston | Florida | Chicago | New Jersey

1-800-931-8628

@ info@dukersusa.com

www.DukersUSA.com