



# BEVERAGE-AIR

Project: _____	AIA#
Item: _____	
Location: _____	SIS#
Approved: _____	

**SPED48HC SANDWICH PREP: STANDARD TOP**

## FOOD PREPARATION TABLES

### SPED48HC Sandwich Prep Table with Drawers

#### Hydrocarbon Series

**MODEL:**  
**SPED48HC-10-4**



**7 Year Parts/Labor Warranty**  
**7 Year Compressor Warranty**

#### CABINET CONSTRUCTION

- Stainless steel front, sides, top, drawers and grille (galvanized back & bottom)
- Interior liner is made of corrosion resistant aluminum
- Full electronic control
- Airflow assures that product in open containers is kept below 41°F and above freezing
- Snap-in magnetic gaskets for positive drawer seal
- Painted aluminum drawer handles
- 10" Wide cutting board constructed of white polyethylene plastic
- Cutting board removable for cleaning
- Ten (10) 1/6 4" deep pans constructed of polycarbonate plastic
- Stainless steel drawer frames supported on telescoping drawer slides
- Drawer slides include locking mechanism that prevents drawers from being inadvertently pulled off cabinet
- Pans furnished are 4" deep constructed of polycarbonate plastic
- 6" Casters, with (2) brakes standard

#### OPTIONS & ACCESSORIES

- Stainless steel back
- Stainless steel interior
- Clear lid
- Overshelves (single or double)
- Crumb catcher kit
- Richlite cutting board
- Night cover
- Bottle organizer
- Pan supports
- Pan support crossbar
- Pan configuration
- Locking divider
- 6" Legs or 3" casters
- Low profile casters
- Remote option\* (see note on back page)

#### REFRIGERATION SYSTEM

- Uses environmentally friendly, energy efficient R290 refrigerant, and meets all regulatory requirements for CARB, SNAP, DOE & more
- Adaptive defrost
- Epoxy coated evaporator coil
- Enhanced airflow maintains temperatures between 36° - 38°F



Please verify qualifying units by visiting:  
[www.energystar.gov/cfs](http://www.energystar.gov/cfs)

3779 Champion Blvd., Winston-Salem, NC 27105  
1-888-845-9800 Fax: 1-336-245-6453  
Beverage-Air.com Sales@bevair.com



# BEVERAGE-AIR

MODEL	SPED48HC-10-4
<b>EXTERNAL DIMENSIONAL DATA</b>	
Width Overall	48"
Depth Overall	32"
Height Overall with Casters	45 1/4"
No. of Drawers	4
Depth with Drawer Open 90°	47 7/8"
Drawer Openings	19 5/8" x 11 1/4" 19 5/8" x 7 1/2"
Width, Cutting Board	10"
<b>INTERNAL DIMENSIONAL DATA</b>	
NET Capacity (cubic ft.)	13.01
Internal Width Overall (in)	44"
Internal Depth Overall (in)	15 3/8"
Internal Height Overall (in)	23"
No. of Pans	10
<b>ELECTRICAL DATA</b>	
Full Load Amperes	2.0
<b>REFRIGERATION DATA</b>	
Horsepower	1/6
Capacity (BTU/Hr)	1094
Heat Rejection (BTU/Hr)	1641
Charge (lbs/grams/ounces)	0.243 / 110 / 3.89
<b>SHIPPING DATA</b>	
Gross Weight - Crated	326 lbs
Height - Crated	46"
Width - Crated	51"
Depth - Crated	33"

\*NOTE: Remote units are field wired and come with 6" legs. Refrigerant must be specified at time of order.

We reserve the right to change specifications and product design without notice. Such revisions do not entitle the buyer to corresponding changes, improvements, additions or replacements for previously purchased equipment. Dimensional tolerances +/- 1/4". Metric dimensions (MM).

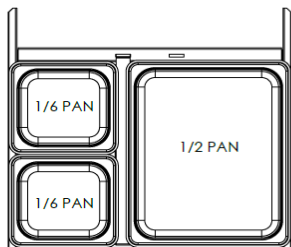

## Food Preparation Table with Drawers: Standard Top Model: SPED48HC-10-4

### Model Views

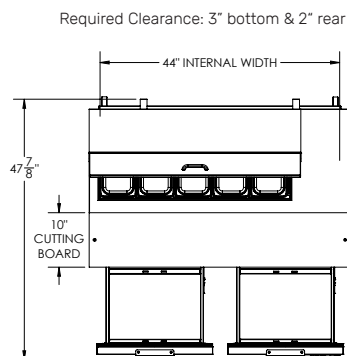

### PLAN VIEW

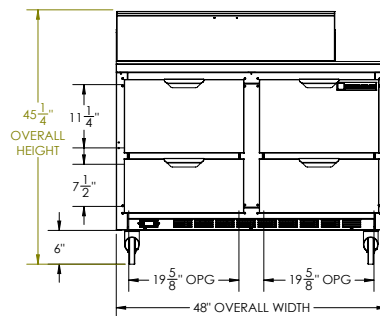

### ELEVATION VIEW

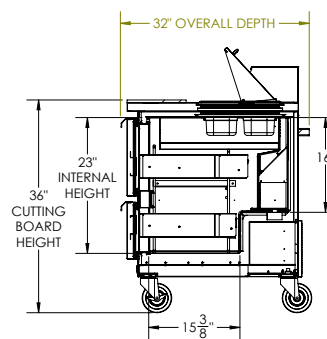

### SIDE VIEW



### ELECTRICAL CONNECTION

115/60/1  
NEMA 5-15P

Unit pre-wired at factory and include 8' long cord and plug set.