



# HURAKAN

## HKN-GXE47R2 - 54" Double Solid Doors

### Reach-In Refrigerators

Item #: HKN-GXE47R2/US Project: \_\_\_\_\_

Qty: \_\_\_\_\_ Date: \_\_\_\_\_ Approval: \_\_\_\_\_



#### Technical Data

Width	54 Inches
Depth	32 1/4 Inches
Height	82 1/2 Inches
Capacity	47 cu. ft
Power Cord Length	98 3/8 Inches
Interior Width	49 3/8 Inches
Right Door Opening Width	22 5/8 Inches
Interior Depth	27 1/8 Inches
Interior Height	51 5/8 Inches

#### Features

- Stainless steel interior and exterior, aluminum back.
- Option of bright white aluminum interior available
- Electronic control makes it easy to adjust temperature set point and defrost frequency.
- Refrigeration system keeps food at safe temperatures between 33F - 41F .
- Preinstalled heavy-duty casters with brakes
- Self-Closing doors with 90 degree stay-open feature Locks and keys included
- Removable installation board makes it easy to access condenser coil for cleaning and service.
- Option of different handles & control panels available
- Adjustable heavy-duty PVC coated shelves

#### Certifications



ETL, US



ETL Sanitation

[www.equip.me](http://www.equip.me)



## Technical Data

Amps	3.8 Amps
Hertz	60 Hertz
Phase	1 Phase
Voltage	110 Volts
Access Type	Doors
Casters	With Casters
Color	Silver
Compressor Location	Bottom Mounted
Construction	Stainless steel interior and exterior, aluminum back
Door Style	Swing
Door Type	Solid
Dutch Half Doors	Without Dutch Half Doors
Features	no
Horsepower	1/4+
Individual Shelf Capacity	88 lb.
Installation Type	Freestanding
Number of Doors	2 Doors
Number of Shelves	6 Shelves
Plug Type	NEMA 5-15P
Refrigerant Capacity	4.59 oz
Refrigerant Type	R-290
Sections	1 Section
Temperature Range	33 - 41 Degrees F



## Plan View

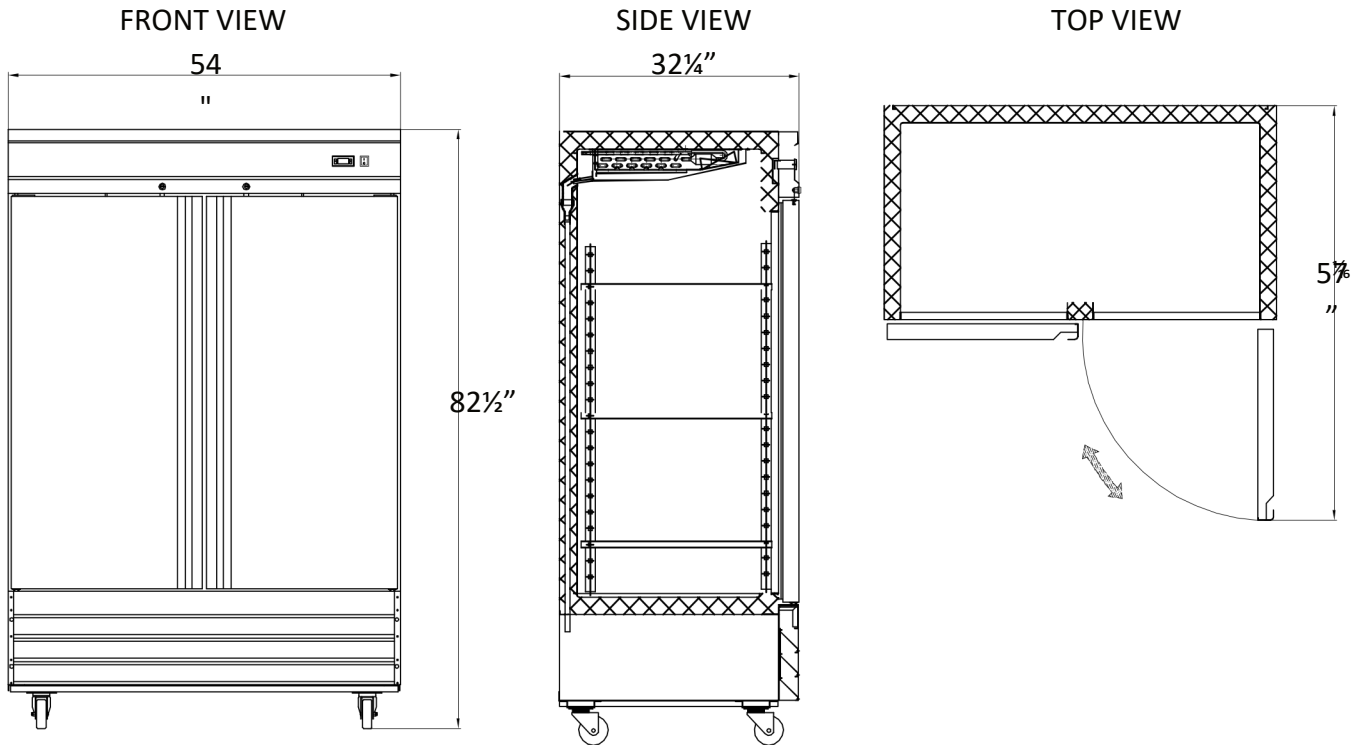

## Notes & Details

Two-Door Reach-In Refrigerator. This Reach-In Freezer features a stainless steel interior and exterior, with an aluminum back. It includes self-closing doors with a 90-degree stay-open feature for convenience. Additionally, there's an option for a bright white aluminum interior. Locks and keys are included for security purposes.

The electronic control system simplifies operation, allowing for easy adjustment of temperature set points and defrost frequency. It also facilitates access to the condenser coil for cleaning and service through a removable installation board.

The refrigeration system maintains food at safe temperatures between 33°F and 41°F. Preinstalled heavy-duty casters with brakes ensure mobility and stability. Furthermore, the unit comes with adjustable heavy-duty PVC-coated shelves. Optional handles and control panels are available for customization.

Dimensions: 54" x 32 1/4" x 82 1/2"

Capacity 47 cu. ft.