

GFX HP 1,5 - 120V

GFX HP 2 - 120V

GFX HP 2 - 230V

GF HP 4 - 230V

Hard cheese graters, heavy-duty

GFX HP 1,5 and Hp 2 models
features a removable hopper for ease of cleaning
Unique in the market!



- Powerful, reliable heavy-duty cheese and bread graters, suitable for medium to large applications.
- Overload and no volt release protection.
- Specially milled stainless steel drum.
- GFX HP 1.5 and Hp 2 with removable hopper for easy cleaning. Unique on the market!
- Handle interlock deactivates unit when hopper is open.

Features

Technical

- The drum is made from milled stainless steel for longer lasting performance and always perfectly grated product output.
- 1/16" tooth for very finely grated product.
- Featuring heavy duty fan cooled motors with overload relay.

Safety

- An interlock prevents the machine from starting when the handle is not lowered enough and stops the machine when the handle is lifted.
- Overcurrent and no volt release protection.

Sanitary

- Removable hopper for ease of cleaning (GFX HP 1,5 and Hp 2 models)
- Plexiglas® catch pan, dishwasher safe.

Optional: Stainless steel catch pan (no GF HP4)

Specifications

Construction:	Stainless steel body with anodized aluminum hopper. Specially milled stainless steel drum.
Output GFX Hp 1,5 - 120V:	Up to 3.6 Lbs./Min.
Output GFX Hp 2 - 230V:	Up to 4 Lbs./Min.
Output GF Hp 4 - 230V:	Up to 8 Lbs./Min.
Electrical GFX Hp 1,5 - 120V:	120V, 60Hz, single-phase, 12A - 1.5 HP
Electrical GFX Hp 2 - 120V:	120V, 60Hz, single-phase, 18A - 2 HP, 14 AWG
Electrical GFX Hp 2 - 230V:	230V, 60Hz, single-phase, 6A - 2 HP, 14 AWG
Electrical GF Hp 4 - 230V:	230V, 60Hz, 3-phase, 16A - 4HP
Overload:	13A GFX HP 1,5 (120V) 20A GFX HP 2 (120V) 16A GFX HP 2 (230V) and GF HP 4
Plug & Cord:	Attached plug, flexible, 3 wire SJTO long cord. 16 AWG NEMA 5-15 P (GFX HP 1,5 - 120V) 14 AWG NEMA 5-20 P (GFX HP 2 - 120V) 18 AWG NEMA 6-15 P (GFX HP 2 - 230V) 12 AWG NEMA 15-20 P - 3-phase (GFX HP 4 - 230V)
Controls, GFX series:	ON/OFF stainless steel keypad. IP 67 waterproof. No voltage release. GFX HP 1,5 - Hp 2: use 10 min ON / 10 Min. OFF
Controls GF Hp 4:	Green ON & Red OFF (0) buttons. No-voltage release.



Certified to UL Standard 763
 Certified to CSA Standard C22.2



GFX Hp 1.5



GF Hp 4



GFX Hp 1.5 and Hp 2
 Optional s/steel tray

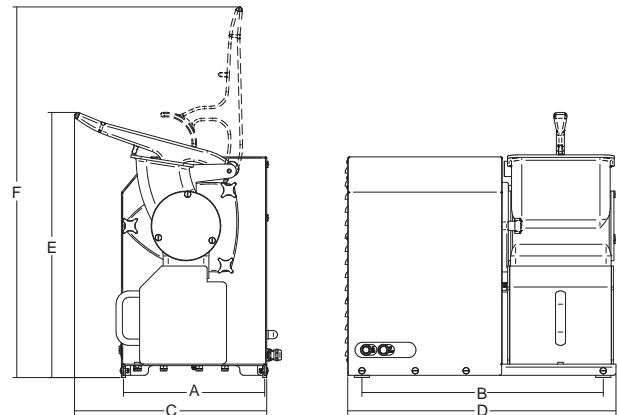

	Power	Power source	Drum revolutions	Mouth dimensions	A	B	C	D	E	F	Net weight	Shipping	Gross weight
	watt/Hp		r.p.m.	inch	inch.	inch.	inch.	inch.	inch.	inch.	lbs.	inch.	lbs.
GFX Hp 1,5	750/1	120V, 60Hz, 12 A	1.680	5 ^{33/64} x 3 ^{3/32} "	10 ^{15/64} "	15 ^{35/64} "	14 ^{9/64} "	17 ^{53/64} "	16 ^{7/32} "	24 ^{1/64} "	55	29" x 14" x 20"	62
GFX Hp 2	1400/2	120V, 60Hz, 18 A 230V, 60Hz, 6 A +/- 10%	1.680	7 ^{1/2} " x 3 ^{3/4} "	10 ^{15/16} "	18 ^{45/64} "	14 ^{7/8} "	20 ^{25/32} "	20 ^{35/64} "	28 ^{47/64} "	75	36" x 36" x 25"	125
GF Hp 4	3000/4	230V, 60Hz, 3-ph, 16 A +/- 10%	1.680	11 ^{13/16} " x 6 ^{5/16} "	13 ^{3/8} "	27 ^{9/16} "	25 ^{3/16} "	29 ^{1/2} "	25 ^{3/16} "	43 ^{5/16} "	139	33" x 34" x 33"	176