

## Type: Tandoor Oven

### Models: TRN0700, TSQ0700, TBR0700

Beech Ovens manufacture the world's most advanced and spectacular Tandoor ovens. Our Tandoors are used by discerning Chefs across the globe and have a reputation for superior performance, energy efficiency and longevity.

Beech Tandoor ovens are manufactured from a high grade castable ceramic material with reinforced metal bands and stainless steel enclosure. The internal diameter of the cooking pot is 700mm (27.6") and it has a 1.01m<sup>2</sup> (10.9ft<sup>2</sup>) cooking surface. All Tandoors are supplied with a traditional ceramic cooking surface. The use of high-tech long lasting ceramics which can withstand high temperatures for prolonged periods allows Beech Tandoors to outlast any other Tandoor oven on the market. Not one of the hundreds of Tandoors that we have sold has suffered a pot failure making Beech the Tandoor choice of leading hoteliers worldwide.

All Beech Tandoors are available as charcoal, gas or electric powered and have a range of external shapes and finishes. Optional finishes include stainless steel, copper or any painted finish including our popular textured terracotta enamel.

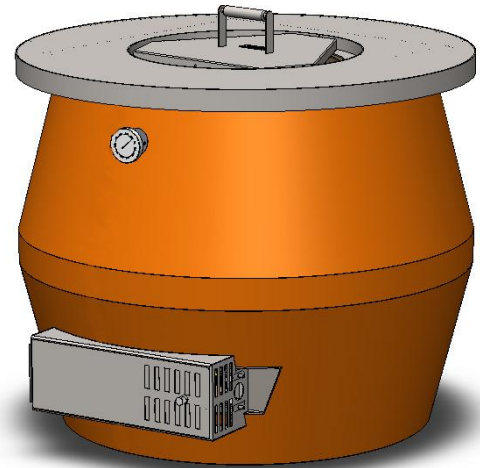

**TBR0700**

## Unique Features

- Traditional ceramic cooking surface.
- Range of external shapes including square, round or barrel.
- Finishes available in stainless steel, copper, terracotta enamel or any other painted colour or finish.
- Easy installation / removal. Ready to operate - no further construction work required.
- Fully insulated and supplied with analogue thermometer and tool kit.
- The first high technology Tandoor; no longer is there a need to replace the internal pot yearly. Typical minimum wall thickness 75mm (3") - twice the thickness of traditional Indian pots.



**TRN0700**

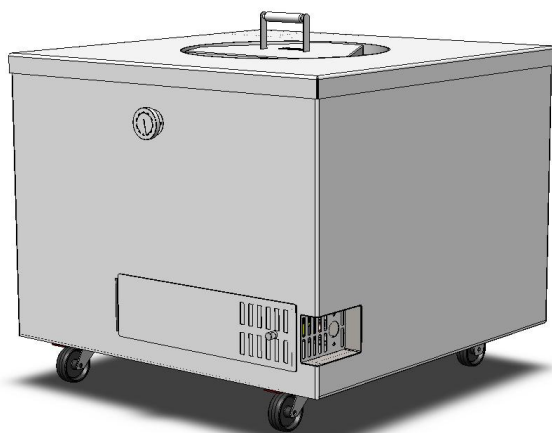

**TSQ0700**

## Optional Accessories

- Removable Roti/Sarj cook top
- Adjustable legs
- Feature barrel shape painted or clad in your choice of material including; copper or patterned stainless steel

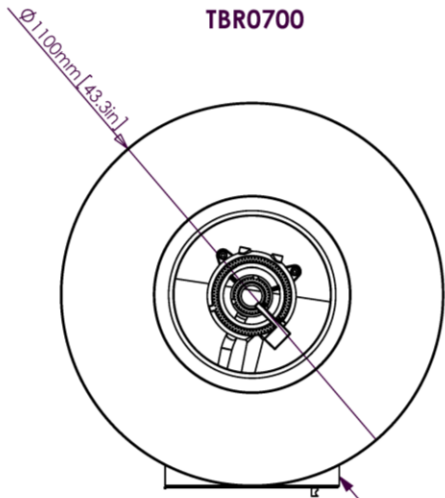

TBR0700

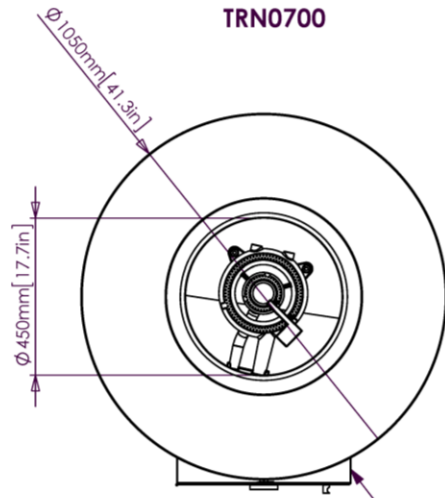

TRN0700

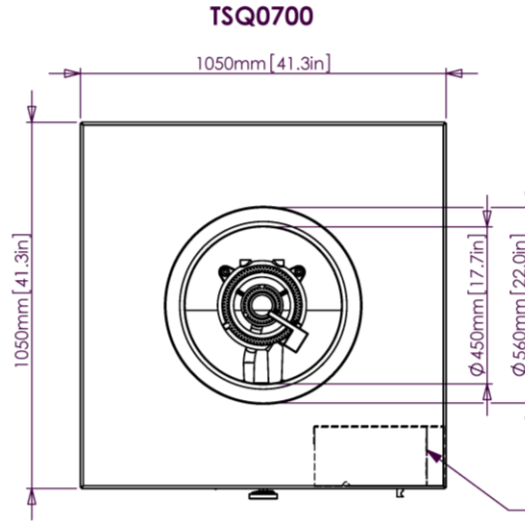

TSQ0700

1200mm [47in] QUICK RELEASE FLEXIBLE HOSE SUPPLIED WITH 15mm (1/2") (M) END CONNECTION (60Mj - 56 000 BTU) - ALL MODELS

1200mm [47in] QUICK RELEASE FLEXIBLE HOSE SUPPLIED WITH 15mm (1/2") (M) END CONNECTION (60Mj - 56 000 BTU) - ALL MODELS

**SERVICES REQUIRED**

- GAS HEAT INPUT 60Mj (56000 BTU)
- 15mm (1/2") GAS LINE CONNECTION (1200mm QUICK RELEASE FLEXIBLE HOSE SUPPLIED)
- ELECTRIC TANDOR - 380-450V 3 PHASE (NO NEUTRAL)
- EXHAUST DUCTING/CANOPY IN ACCORDANCE WITH LOCAL REGULATIONS

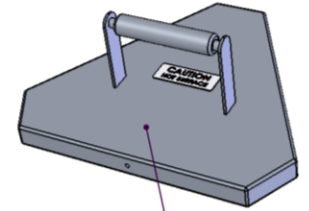

TYPICAL LID

1200mm [47in] QUICK RELEASE FLEXIBLE HOSE SUPPLIED WITH 15mm (1/2") (M) END CONNECTION (60Mj - 56 000 BTU) - ALL MODELS

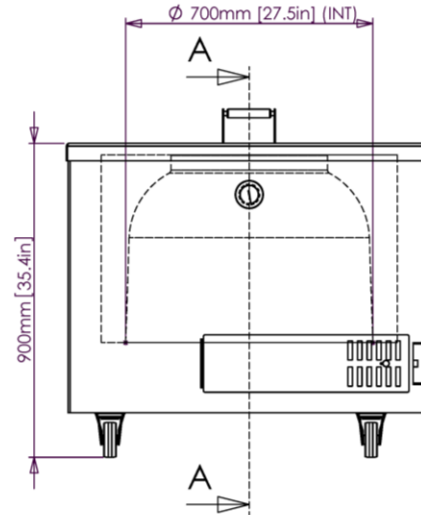
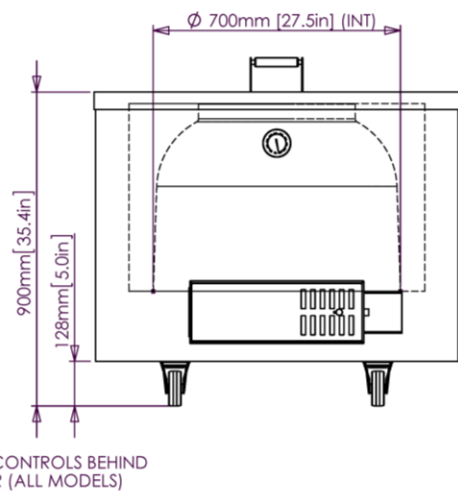
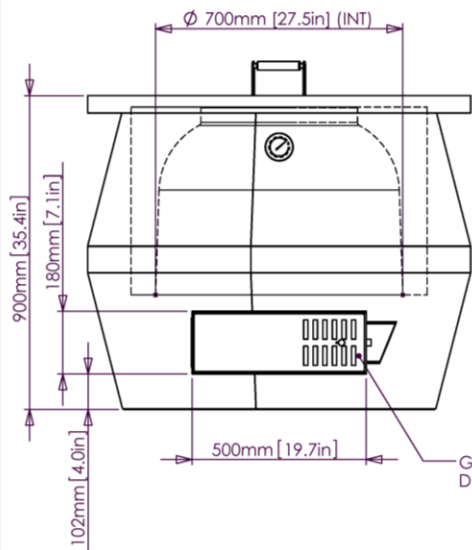

BURNER COVER (ALL MODELS)

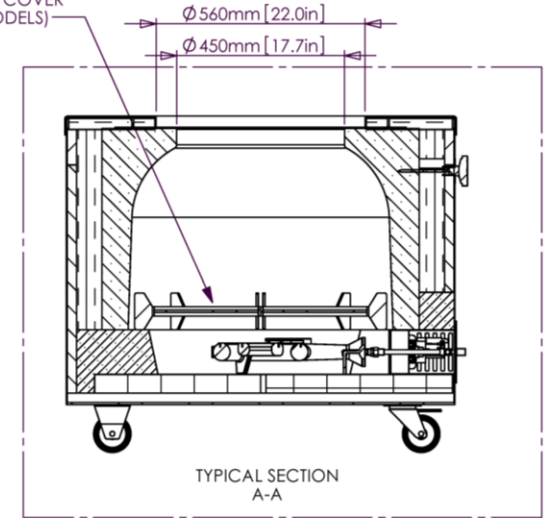

TYPICAL SECTION A-A

REV.	DESCRIPTION OF CHANGES	DATE	CHANGED BY
0	ISSUED FOR CONSTRUCTION		

LAST EDITED: Monday, 12 December 2011 8:24:46 PM

©Copyright 2006 Beech Ovens Pty Ltd. All rights reserved.



Drawn S Trood	Checked	Scale 1:15	Date 12/12/2011
TBR0700 - TRN0700 - TSQ0700 Ø700mm (27.5") INTERNAL STANDARD			<b>A3</b> NTS - SITE MEASURE
<b>TANDOR Ø700 INTERNAL SPEC SHEET - DETAILS</b>			