



Modular conveyor oven

TT96E, the electric modular conveyor oven, is composed of one or more **stackable baking chambers** and an optional stand. During baking, the product is placed on the conveyor belt and passes through two flows of hot air: **impingement technology**, the best system for heat distribution in the whole baking chamber for **perfect baking of pizza, pastry, bakery, and gastronomy**. Management of needed power is automatic according to the load. The power control of ceiling and floor is independent and managed by two probes. The conveyor speed is adjustable. Efficiently insulated and isolated, the external surfaces are cool even during use. The baking chamber maximum temperature is 320°C (608°F).



OPERATION

- Heated by armoured heating elements powered independently in adaptive mode
- Control of power PID (Proportional Supplementary Derivative) can allow the automatic regulation of energy necessary on the basis of the quantity of the batch product and the position inside the baking chamber ADAPTIVE-POWER® TECHNOLOGY
- Independent adjustment and control of ceiling and floor, both on the input side and the output one of the baked product, with continuous temperature detection using 4 high sensitive thermocouples QUADRA-TEMP™ TECHNOLOGY
- Air blowing system using 2 stainless steel fans independently motorized
- Conveyor belt with speed adjustable from 45" to 20 minutes using Brushless engine at the option of belt standstill
- Programmable electronic function management ECO-SMARTBAKING®
- Maximum temperature reached 608°F
- Independent system for additional forced air cooling of the components with low noise

CONSTRUCTION

- Structure in folded stainless steel sheets
- Stainless steel door hinged on left hand side with logo BlackBar® Design
- Stainless steel access flap hinged at bottom
- Tempered glass window
- Low-cluttered handle
- Extractable stainless steel conveyor belt, with continuous tensioning
- Electronic control panel on front left side
- Baking chamber in stainless steel sheets
- Top and bottom blowers in welded stainless steel sheets, extractable for cleaning
- Rock wool heat insulation, thermal joints and air space COOL AROUND® Technology

ACCESSORIES

- Stand with castors, height 5 3/8", 23 1/2" complete with pocket for screens
- Hood for vapour extraction
- Online connection Remote-Master® Technology

BAKING DIMENSIONS

Belt width L	25 3/4"
Internal length	35 3/4"
Total length P	81"
Total length P with pizza rest	97 1/2"
Tot. baking surface	6,4ft ²

STANDARD EQUIPMENT

- Color multilanguage display TFT 5"
- 100 customisable programs
- ECO-STAND BY™ TECHNOLOGY Saving device with the possibility to stop the belt for break
- Discontinuous baking cycle STEP
- Double pass baking cycle RETURN
- Start-Stop function to move tape to the set point is reached
- LOCK function
- Weekly Timer with the possibility to program two lightings and two power off every day
- Customized Hotkey with recurring control
- Auto test with display of error message
- USB input for sw update
- Double independent maximum temperature and minimum blow pressure safety devices
- Stainless steel resting support

TOP VIEW

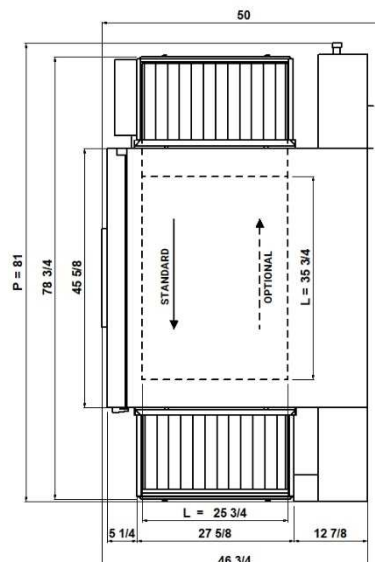

1 baking chamber
(assembled with stand height 23 1/2")

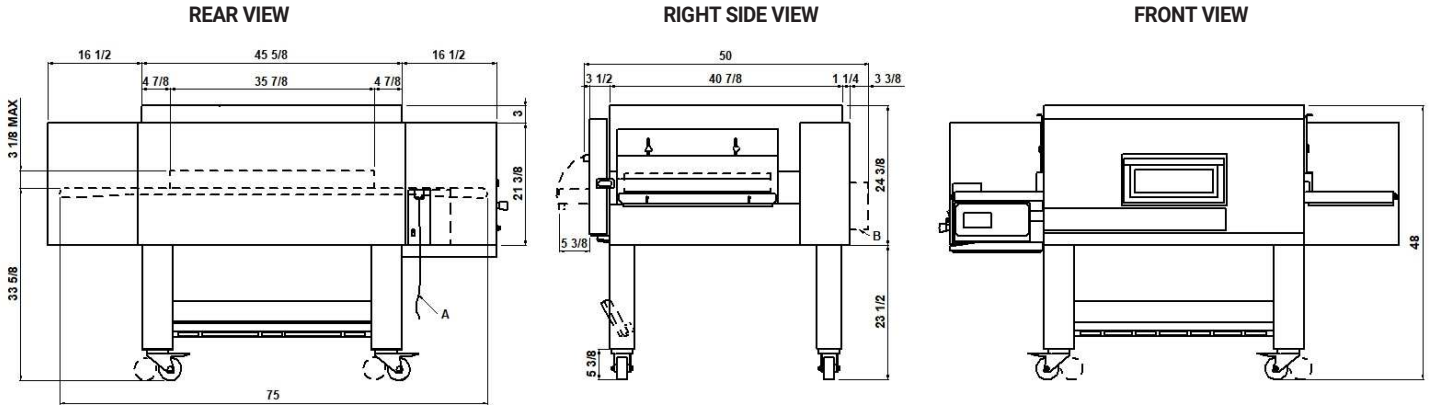

NOTE: The dimensions indicated in the views are in inches.

A	B		
Electrical cable length 6,5ft	fairlead		

DIMENSIONS

External height.	48" (1220mm)
External depth	50" (1269mm)
External width	81" (2050mm)
Weight(excl.stand)	655lb (297kg)

TOTAL BAKING CAPACITY

*N° Pizzas /hour	
Pizzas diameter 13"	N°100
Pizzas diameter 18"	N°38

SHIPPING INFORMATION

Dimensions of packed oven	
Height	31 1/4" (790mm)
Depth	52 1/4" (1325mm)
Width	84 3/4" (2152mm)
Weight	710lb (322kg)

Packaged stand dimensions:

Height	8" (200mm)
Depth	23 1/2" (600mm)
Width	45" (1150mm)
Weight	67lb (30kg)

FEEDING AND POWER

Standard feeding	
A.C. V240 3ph	
Feeding on request	
A.C. V208 3ph	
Frequency	60Hz
Max power	17,8kW/DECK
*Medium cons/hour	7,8kWh/DECK
Ampère max	
45,1A/DECK V240 3ph	
51,6A/DECK V208 3ph	

Connecting cable for each chamber
6AWG/DECK (V240 3ph)
6AWG/DECK (V208 3ph)
(EACH DECK NEEDS TO BE CONNECTED INDEPENDENTLY AND THE LOAD SHOWN BELOW ARE PER DECK)

* This value is subject to variation according to the way in which the equipment is used
NOTE: MORETTI FORNI S.P.A. reserves the right to modify the characteristics of the products illustrated in this publication without prior notice

2 baking chambers

(assembled with stand height 23 1/2")

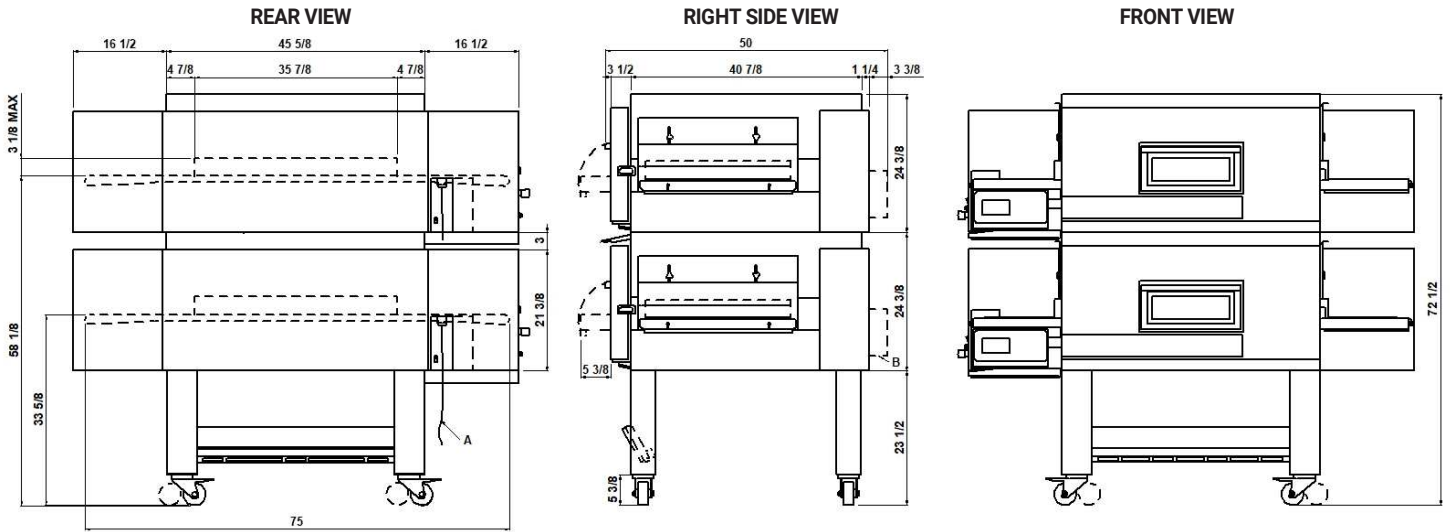

NOTE: The dimensions indicated in the views are in inches.

A	B
Electrical cable length 6,5ft	fairlead

DIMENSIONS

External height.	72 1/2" (1840mm)
External depth	50" (1269mm)
External width	81" (2050mm)
Weight(excl.stand)	1310lb (594kg)

TOTAL BAKING CAPACITY

*N° Pizzas /hour	
Pizzas diameter 13"	N°200
Pizzas diameter 18"	N°76

SHIPPING INFORMATION

Packed oven (each packed deck)	
Height	2x31 1/4" (2x790mm)
Depth	52 1/4" (1325mm)
Width	84 3/4" (2152mm)
Weight	1420lb (644kg)

Packaged stand dimensions:

Height	8" (200mm)
Depth	23 1/2" (600mm)
Width	45" (1150mm)
Weight	67lb (30kg)

FEEDING AND POWER

Standard feeding	
A.C. V240 3ph	
Feeding on request	
A.C. V208 3ph	
Frequency	60Hz
Max power	17,8kW/DECK
*Medium cons/hour	7,8kWh/DECK

Ampère max	
45,1A/DECK V240 3ph	
51,6A/DECK V208 3ph	

Connecting cable for each chamber
6AWG/DECK (V240 3ph)
6AWG/DECK (V208 3ph)

(EACH DECK NEEDS TO BE CONNECTED INDEPENDENTLY AND THE LOAD SHOWN BELOW ARE PER DECK)

* This value is subject to variation according to the way in which the equipment is used

NOTE: MORETTI FORNI S.P.A. reserves the right to modify the characteristics of the products illustrated in this publication without prior notice

3 baking chambers
(assembled with stand height 5 3/8")

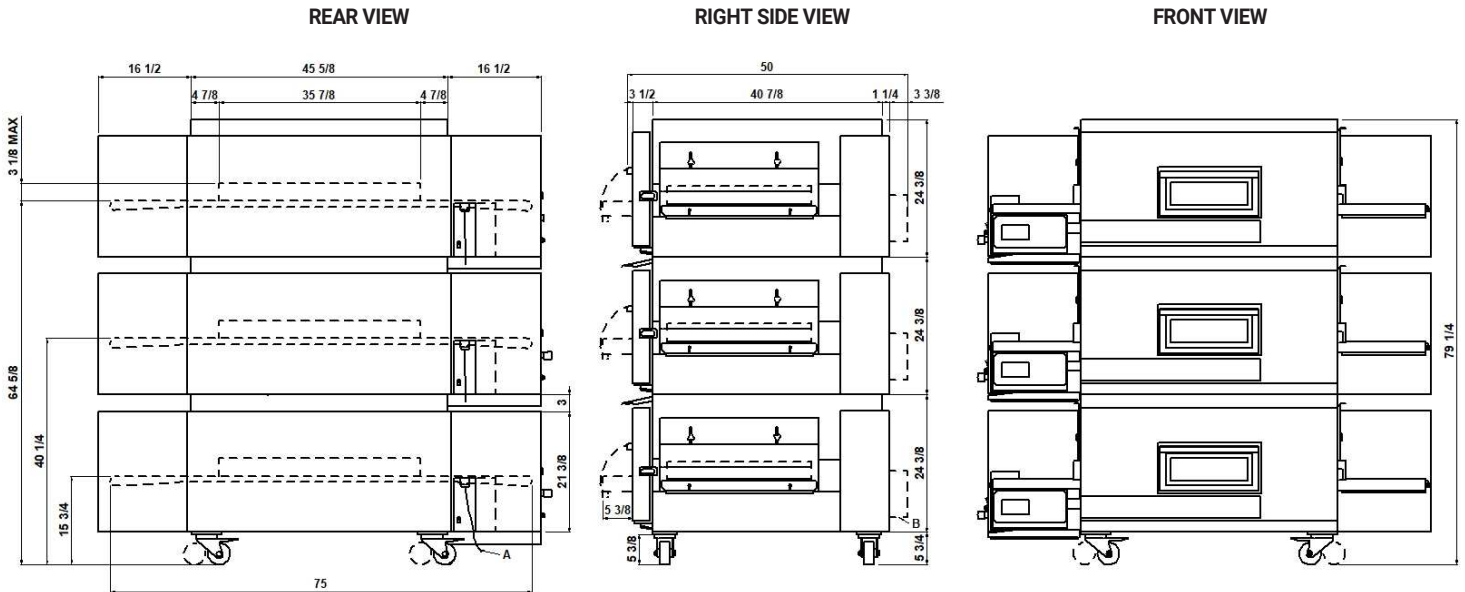

NOTE: The dimensions indicated in the views are in inches.

A	B		
Electrical cable length 6,5ft	fairlead		

DIMENSIONS

External height.	79 1/4" (2013mm)
External depth	50" (1269mm)
External width	81" (2050mm)
Weight(excl.stand)	1965lb (891kg)

TOTAL BAKING CAPACITY

*N° Pizzas /hour	
Pizzas diameter 13"	N°300
Pizzas diameter 18"	N°114

SHIPPING INFORMATION

Packed oven (each packed deck)	
Height	3x31 1/4" (3x790mm)
Depth	52 1/4" (1325mm)
Width	84 3/4" (2152mm)
Weight	2130lb (966)kg

Packaged stand dimensions:

Height	11" (280mm)
Depth	16 1/2" (420mm)
Width	10 3/4" (270mm)
Weight	39lb (17kg)

FEEDING AND POWER

Standard feeding	
A.C. V240 3ph	
Feeding on request	
A.C. V208 3ph	
Frequency	60Hz
Max power	17,8kW/DECK
*Medium cons/hour	7,8kWh/DECK
Ampère max	
45,1A/DECK V240 3ph	
51,6A/DECK V208 3ph	

Connecting cable for each chamber
6AWG/DECK (V240 3ph)
6AWG/DECK (V208 3ph)
(EACH DECK NEEDS TO BE CONNECTED INDEPENDENTLY AND THE LOAD SHOWN BELOW ARE PER DECK)

* This value is subject to variation according to the way in which the equipment is used
NOTE: MORETTI FORNI S.P.A. reserves the right to modify the characteristics of the products illustrated in this publication without prior notice