

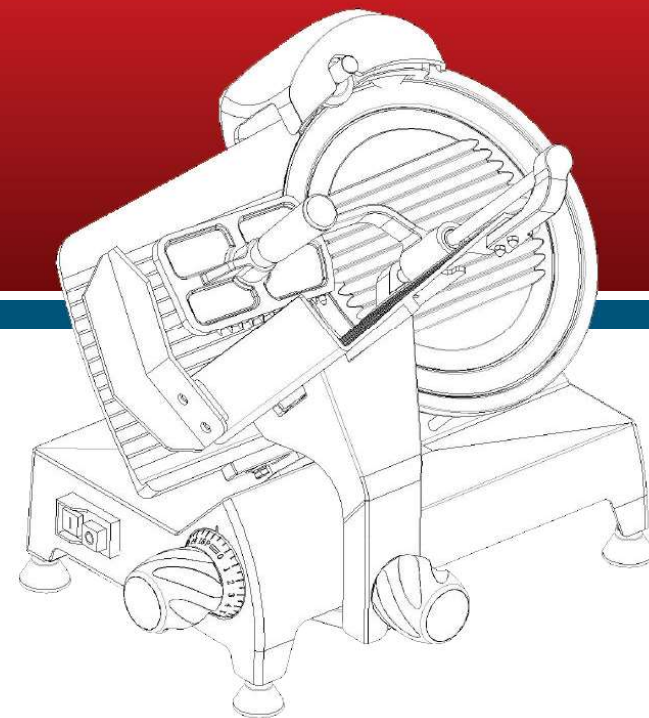

INSTRUCTIONS MANUAL



Skyfood Equipment LLC

OFFICE

11900 Biscayne Blvd. Suite 616 - North Miami, FL 33181 - USA

1-800-503-7534 | 305-868-1603

UG0214 - ENGLISH

Data de Correção: 03/05/2023

MEAT SLICERS

GL200F

GL250F

GL300F

312 ECF

- BESIDES THIS EQUIPMENT, A COMPLETE RANGE OF OTHER PRODUCTS ARE MANUFACTURED, CONSULT OUR DEALERS
- DUE TO THE CONSTANT IMPROVEMENTS INTRODUCED TO OUR EQUIPMENTS, THE INFORMATION CONTAINED IN THE PRESENT
INSTRUCTION MANUAL MAY BE MODIFIED WITHOUT PREVIOUS NOTICE.

www.skyfood.us

SUMMARY

- 1. INTRODUCTION 3**
- 2. UNPACKING 5**
- 3. REPACKING INSTRUCTIONS 5**
- 4. GETTING TO KNOW YOUR MEAT SLICER 6**
- 4.1 Replacement Parts..... 6
- 5. OPERATING YOUR MEAT SLICER 7**
- 5.1 Food Slicing Tips 8
- 5.2 Blade Sharpening Tips..... 9
- 6. CLEANING YOUR MEAT SLICER 10**
- 6.1 To Disassemble Slicer.....10
- 6.2 Storage12
- 6.3 Adjusting the Sliding Food Carriage.....12
- 7. General Safety Practices 13**
- 7.1 Basic Operation Procedures13
- 7.2 Safety Procedures and Notes before Switching the Machine ON14
- 7.3 Routine Inspection.....14
- 7.4 Operation15
- 7.5 After Finishing The Work.....15
- 7.6 Maintenance15
- 7.7 Warning.....15
-
- SKYFOOD EQUIPMENT LLC - SERVICE 16**
- SKYFOOD’S LIMITED WARRANTY 16**

Warranty Registration



Questions about how to complete this form?

Call 1-800-503-7534 / 305-868-1603

Return completed form to:

SKYFOOD EQUIPMENT LLC
11900 Biscayne Blvd. Suite 616
North Miami, FL 33181 - USA

Or fax form to:

305-866-2704

User Details

* Contact Person: _____

* Business type:

- | | |
|--|---|
| <input type="checkbox"/> Bakery and Bagel Operations | <input type="checkbox"/> Mass Merchandiser with Grocery |
| <input type="checkbox"/> Bakery (Associated with Restaurant) | <input type="checkbox"/> Mass Merchandiser with NO Grocery |
| <input type="checkbox"/> Bowling Center | <input type="checkbox"/> Meat Packer and Purveyor |
| <input type="checkbox"/> Business and Industry In-House Feeding | <input type="checkbox"/> Other Business that prepares or serves food |
| <input type="checkbox"/> Butcher | <input type="checkbox"/> Other Business that sells but doesn't serve food |
| <input type="checkbox"/> Catering | <input type="checkbox"/> Pizza (Dine In / Carry Out) |
| <input type="checkbox"/> Club Stores | <input type="checkbox"/> Restaurants (Independent / Chain) |
| <input type="checkbox"/> Convenience Store | <input type="checkbox"/> School |
| <input type="checkbox"/> Country Club | <input type="checkbox"/> Stadiums / Coliseum |
| <input type="checkbox"/> Delicatessen (Chain / Restaurant) | <input type="checkbox"/> Supermarket / Grocery |
| <input type="checkbox"/> Delicatessen (Independent and Non-Restaurant) | <input type="checkbox"/> Theme Park |
| <input type="checkbox"/> Food Store | <input type="checkbox"/> University / College |
| <input type="checkbox"/> Government | <input type="checkbox"/> Vineyard / Winery |
| <input type="checkbox"/> Hospital | <input type="checkbox"/> Warehouse Clubs |
| <input type="checkbox"/> Lodging | <input type="checkbox"/> Wholesale Baking Operation (Non-Institutional) |

* Company Name: _____

* Address: _____

* City: _____

* State: _____ * Zip Code: _____

* Phone: _____ Fax: _____

** E-mail: _____

Web page: _____

- I would like to join the Mail List. I would like to join the E-mail List.

Product Details

* Product Commercial Item: _____

The Product Commercial Item can be found on the machine Product Identification Label.

* Serial Number: _____ * Confirm Serial Number: _____

This information, the Product Serial Number, can also be found on the machine Product Identification Label.

* Proof of Purchase: Yes
 No

* Purchased On: ____ / ____ / ____ (mm / dd / yyyy)

* Purchased From: _____
Company Name

* Indicates required field. ** Indicates required field, not mandatory by Fax.

1. INTRODUCTION

IMPORTANT SAFEGUARDS

When using electrical appliances, basic safety precautions should always be followed, including the following:

1 . READ ALL INSTRUCTIONS.

2. **CHECK FOR DAMAGED PARTS.** Before using the Meat Slicer, check that all parts are operating properly and perform the intended functions. Check for alignment of moving parts, binding of moving parts, mounting and any other conditions that may affect the operation.

3. Unplug power cord from outlet when not in use, before putting on or taking off parts, and before cleaning; Blade is exceptionally sharp. Handle very carefully.

4. This appliance is **NOT** intended for use by persons (including children) with reduced physical, sensory or mental capabilities, or lack of experience and knowledge, unless they have been given supervision or instruction concerning use of the appliance by a person responsible for their safety. Children should be supervised to ensure that they do not play with the appliance.

5. NEVER LEAVE MEAT SLICER UNATTENDED WHILE IT IS RUNNING!

6. Avoid contact with moving parts. **NEVER PUT YOUR FINGERS NEAR THE BLADE WHILE IT IS IN OPERATION.**

7. Never put the unit near a hot burner, in an oven or in a dishwasher. **NOT DISHWASHER SAFE.**

8. **DO NOT** operate the Meat Slicer, or any other electrical equipment, with a damaged cord or plug or after the unit malfunctions. Return unit to the Authorized Service Center for examination, repair, or adjustment.

9. **DO NOT** use outdoors. This product is intended for Household Use Only.

10. **DO NOT** let cord hang over the edge of a table or counter, come into contact with sharp edges, or touch hot surfaces.

11. **DO NOT** let cord become kinked, trapped under or let it wind around the slicer.

12. **DO NOT PULL** the power cord to disconnect.

13. To reduce the risk of electric shock, this product has a polarized plug (one prong is wider than the other). The plug is intended to fit in a polarized outlet only one way. When the plug does not fit fully in the outlet, reverse the plug. If it still does not fit, contact a qualified electrician to install the proper outlet. **DO NOT** make changes to the plug in any way.

14. Place the appliance on a firm and stable surface. Ensure that the appliance is not placed near the edge of the worktop, where it can be easily pushed off or fall.

15. **DO NOT** operate your slicer in an appliance garage or under a wall cabinet. When storing in an appliance garage, always unplug the unit from the electrical outlet. Not doing so could create a risk of fire, especially if the appliance touches the walls of the garage or the door touches the unit as it closes.

16. **NEVER** plug in the appliance where water may flood the area.

17. To protect against risk of electrical shock, do not put appliance in water or other liquids.
18. **DO NOT** operate Meat Slicer with wet hands or while standing on a wet floor. **DO NOT** use the Meat Slicer if it is wet or moist.
19. The use of attachments not recommended or sold by the manufacturer may cause fire, electric shock or injury.
20. **NEVER** use abrasive cleaning agents or abrasive cloths when cleaning the unit.
21. Use the slicer to cut **ONLY** designated food. Do not attempt to slice frozen food, bones, cardboard, plastic, etc.
22. **DO NOT** use appliance for other than intended use.
23. The Commercial Grade Food Slicer has a sharp blade. To avoid injury, never hand-feed food to be sliced. Always use the unit when completely assembled with food carriage and food pusher.
24. Touch the blade **ONLY** when the power is OFF to remove and clean according to instructions.
25. Follow instructions when lifting or moving the Meat Slicer.
26. When the blade is moving, place hands on the recommended push surface only.
27. After re-attaching the removable carriage, never use the slicer unless it is fully upright and completely assembled.
28. To avoid accidental contact with the blade when the slicer is not in use or when lifting the slicer, always turn Adjustable Thickness Knob (2) to "O" so that the Adjustment Plate (3) covers the edge of the blade.
29. When lifting the slicer, carefully position your body to avoid contact with the blade.
30. **DO NOT** use while under influence of drugs or alcohol.
31. The Manufacturer declines any responsibility in the case of improper use of Food Slicer. Improper use of the Meat Slicer voids the warranty.

WARNING

Before cleaning, assembling or disassembling the MEAT SLICER, check the plug and make sure PLUG IS REMOVED FROM THE OUTLET/POWER SOURCE!

WARNING

HANDLE CAREFULLY! KEEP FINGERS AWAY FROM BLADE. NEVER USE FINGERS TO FEED FOOD BY HAND. ALWAYS USE THE THE FOOD CARRIAGE! Always use the meat slicer completely assembled with food carriage and food pusher. Use protective cut-resistant gloves whenever handling the blade.

above.

All products held at non-commercial facilities or domiciles, must be taken or shipped, shipping charges prepaid, either to SKYFOOD's facility or a SKYFOOD's designated service company ("Service Company"). Products held at commercial facilities and weighing less than seventy (70) lbs. must be taken or shipped, shipping charges are prepaid, either to SKYFOOD's facility or to a Service Company. Mileage or travel time will NOT be paid. SKYFOOD offers a limited on-site warranty for products ONLY held at commercial facilities, whose net weight exceeds seventy (70) lbs., provided they are installed in a location that is within a thirty (30) mile radius of a Service Company. **End Users are responsible for all extra travel and mileage rates.** In this case, warranty services will be provided during regular business hours.

This product will be replaced or repaired under warranty, for a period of (1) year, beginning from the date of purchase by the original purchaser/user ("End User"), or eighteen (18) months from the date of shipment from SKYFOOD's warehouse, whichever expires first.

Accessories will be replaced or repaired under warranty, for a period of (30) days, beginning from the date of purchase by the original purchaser/user ("End User"), or eighteen (18) months from the date of shipment from SKYFOOD's warehouse, whichever expires first.

This warranty shall not take effect until a properly completed and executed **WARRANTY REGISTRATION** form has been received by SKYFOOD EQUIPMENT, LLC, within thirty (30) days from the date of purchase. The **WARRANTY REGISTRATION** is available either in the Instruction Manual of every Product or at SKYFOOD's website www.skyfood.us. The End User must fill out the **WARRANTY REGISTRATION** form and send it to SKYFOOD according to the instructions posted on the referred website. **Failure to do so will VOID the warranty.**

No extended warranties for third party products. There are no other express warranties or conditions other than the one offered by each manufacturer for products sold by SKYFOOD, not under the SKYFOOD brand.

For questions or assistance, do not return the product or accessories to the store, please call Toll Free 1-800-503-7534, or visit the Customer Service section at www.skyfood.us. For faster service please have the items name, serial number, and proof of purchase for the operator to assist you.

SKYFOOD reserves the right to change the terms of its limited warranty at any time without any prior notice. It also reserves the right to change the design and specifications of its equipment or any related documentation at any time. The end user is not entitled to upgrades or refunds resulting from these changes.

Updates

These **Terms and Conditions** were last updated on March 1st, 2015.

SKYFOOD EQUIPMENT LLC - SERVICE

For questions or assistance, call SKYFOOD EQUIPMENT Toll Free: **1-800-503-7534**, or visit the Customer Service section at **www.skyfood.us**.

SKYFOOD'S LIMITED WARRANTY

Unless otherwise specified, new **SKYFOOD** products, excluding accessories, sold by SKYFOOD EQUIPMENT, LLC. ("SKYFOOD"), for use only in the continental United States (collectively, "Products" or singularly, "Product"), are warranted to be free from defects in materials and workmanship for a period of one (1) year from the date of purchase by the original purchaser/user ("End User"), or eighteen (18) months from the date of shipment from SKYFOOD's warehouse, whichever expires first. Several new products and accessories may be warranted for a period other than one (1) year while others may be subject to travel limitations, as specified on the products Instruction Manual. **Proof of purchase must be presented; if not this warranty will be VOID.** No warranty is given or implied to a subsequent transferee or any other third party. This warranty is expressly conditional upon SKYFOOD being notified of any defects in materials or workmanship within five (5) days of its occurrence, within the warranted time period. If a notice of a claim under this warranty is timely made by the End User, SKYFOOD or a SKYFOOD's designated service company ("Service Company"), will repair or replace the Product, at SKYFOOD's discretion, subject to the additional conditions hereinafter described.

This warranty shall not apply if damage occurs from improper installation or maintenance performed by an unauthorized service company ("Service Company"), wrong voltage, nor to the extent that Products or parts have been used other than in conformance with operating and maintenance instructions, subjected to misuse or abuse or damaged by accident, acts of God, abnormal use, stress or any other matter unrelated to SKYFOOD, and beyond its reasonable control. **This warranty does NOT cover service labor and travel to perform adjustments on products and/or accessories.** In addition to wear and tear of certain items, such as, but not limited to; glass parts, blades, stones, chopper cutting knives, plates, slicing knives, cutting disc, gaskets, oil changes, sealing tape, heat seal wires, worm gears, self-lubricating bushings, carbon brushes for electric motors, and other parts expendable by nature and that need to be replaced frequently. **Electrical components are subject to natural wear and tear, and are NOT covered by this warranty. THIS WARRANTY EXCLUDES ALL ORAL, STATUTORY, EXPRESS OR IMPLIED WARRANTIES WHICH MAY BE APPLICABLE TO SKYFOOD, INCLUDING, BUT NOT LIMITED TO, ANY IMPLIED WARRANTY OF MERCHANTABILITY AND FITNESS FOR PARTICULAR PURPOSE.** Under no circumstances shall SKYFOOD be liable for loss of use, revenue or profit or for incidental or consequential damages. SKYFOOD shall under no circumstances be liable for any loss, damage, concealed damage, expense or delay of goods for any reason when said goods are in the custody, possession or control of third parties selected by SKYFOOD to forward, enter, clear, transport, or render other services with respect to such goods. The sole and exclusive remedy for breach of any warranty is limited to the remedies provided in the paragraph

2. UNPACKING

1. IMPORTANT: To avoid injury when unpacking the unit, please follow these instructions.
2. Put the box on a large, sturdy flat surface.
3. Remove the instruction book and other literature.
4. Slide poly-foam packing up and off the unit. Lift slicer out of box and place on sturdy flat surface.
5. Remove the protective bag.
6. To lift and move the unit, bend your knees to avoid back injuries and place one hand on the bottom of the motor housing and the other one under the carriage of the meat slicer.
7. Remove orange blade guards from the cutting blade before turning the unit on.
8. Please use extreme caution when handling the blade. We suggest you save all the packing material in the event that future shipping of the machine is needed.
9. Keep all plastic bags away from children.

3. REPACKING INSTRUCTIONS

10. Put food slicer on a large, sturdy flat surface.
11. Put food slicer into plastic bag.
12. Position poly-foam inserts on each end of the food slicer.
13. Put the packaged unit into the upright box.
14. Replace top corrugated insert, instruction book and other literature.

4. GETTING TO KNOW YOUR MEAT SLICER

- 1 - Safety On/Off (I/O) Button (Red & Green)
- 2 - Thickness Adjustment Knob
- 3 - Adjustment Plate
- 4 - Carriage Removal Knob
- 5 - Sliding Food Carriage
- 6 - Housing
- 7 - Non-skid Feet
- 8 - Blade
- 9 - Blade Guard
- 10 - Blade Sharpener (removable)
- 11 - Food Pusher Handle
- 12 - Food Pusher Arm
- 13 - Bottom
- 14 - Blade Guard Knob

FIGURE 01

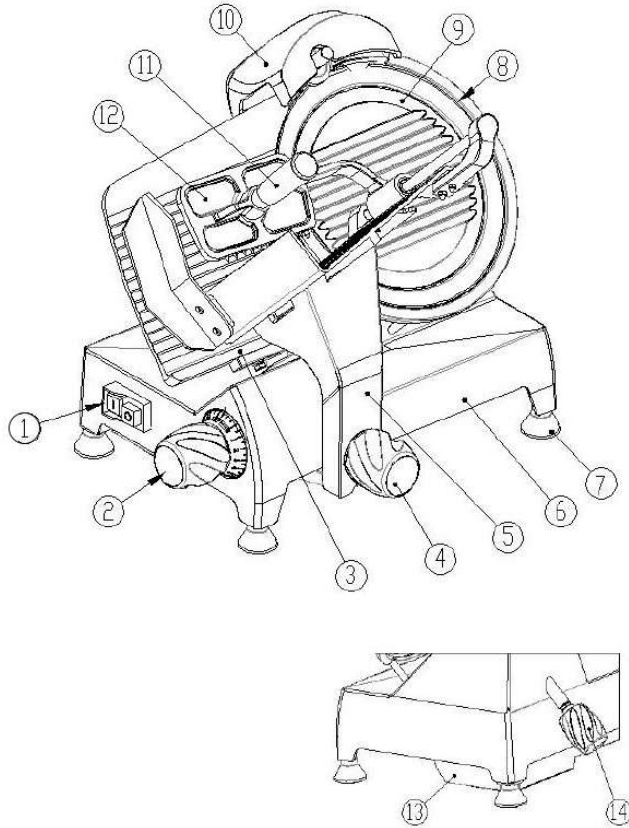

4.1 Replacement Parts

#5	Sliding Food Carriage	#7	Non-skid Feet
#8	Blade	#9	Blade Guard
#10	Blade Sharpener		

WARNING

Read carefully and understand all instructions before operating. Failure to follow the safety rules and other basic safety precautions may result in serious personal injury. Save these instructions in a safe place and on hand so that they can be read when required.

7.3.2 Precautions

Check the motor and sliding or turning parts of the machine in case of abnormal noises. Check the tension of the belts and chains and replace the set when belts or chains show signs of wearing.

When checking the tension of belts or chains DO NOT insert your fingers between belts and pulleys, nor between the chains and gears.

Check protections and safety devices to make sure they are working properly.

7.4 Operation

7.4.1 Warnings

Do not use the machine with long hair that could touch any part of the machine. This might lead to a serious accident. Tie your hair up well and/or cover it with a scarf.

Only trained or skilled personnel shall operate this machine.

Never touch turning parts with your hands or any other way,

NEVER operate the machine without any original safety devices under perfect conditions.

7.5 After Finishing The Work

7.5.1 Precautions

Always TURN THE MACHINE OFF before cleaning by removing the plug from the socket.

Never clean the machine unless it has come to a complete stop.

Put all the components back to their functional positions before turning the machine ON again.

Check the level of liquids.

Do NOT insert your fingers in between belts and pulleys nor chains and gears.

7.6 Maintenance

7.6.1 Danger

Any maintenance with the machine in working situation is dangerous. TURN IT OFF BY PULLING THE PLUG OFF THE SOCKET DURING MAINTENANCE.

IMPORTANT

Always remove the plug from the socket in any emergency situation.

7.7 Warning

Electrical or mechanical maintenance has to be undertaken by qualified personnel.

The person in charge of maintenance has to be sure that the machine is under TOTAL SAFETY conditions when working.

given for each operation step. Every step of the operation shall be taken only if a sign has been made and responded.

7.1.3 Advices

- * In case of power shortage, immediately switch the machine off.* Use recommended or equivalent lubricants, oils or greases.
- * Avoid mechanical shocks, once they may cause damages or bad functioning.
- * Avoid water, dirt or dust contact to the mechanical and electrical components of the machine.
- * DO NOT change the standard characteristics of the machine.
- * DO NOT remove, tear off or maculate any safety or identification labels stuck on the machine. If any labels have been removed or are no longer legible, contact your nearest dealer for replacement.

7.2 Safety Procedures and Notes before Switching the Machine ON

IMPORTANT

Carefully read ALL INSTRUCTIONS of this manual before turning the machine ON. Be sure to well understand all the information contained in this manual. If you have any question contact your supervisor or your nearest Dealer.

7.2.1 Danger

An electric cable or electric wire with damaged jacket or bad insulation might cause electrical shocks as well as electrical leak. Before use, check the conditions of all wires and cables.

7.2.2 Advices

Be sure to well understand all the information contained in this manual. Every operation function or procedure has to be thoroughly clear.

Before using any commands (switch, buttons, lever), be sure it is the correct one. In case of doubt, consult this manual.

7.2.3 Precautions

The electric cable has to be compatible with the power required by the machine.

Cables touching the floor or close to the machine need to be protected against short circuits.

7.3 Routine Inspection

7.3.1 Advice

When checking the tension of the belts or chains, DO NOT insert your fingers between the belts and the pulleys and nor between the chain and the gears.

WARNING

Before cleaning, assembling or disassembling the MEAT SLICER, check the plug and make sure PLUG IS REMOVED FROM THE OUTLET/POWER SOURCE!

WARNING

HANDLE CAREFULLY! KEEP FINGERS AWAY FROM BLADE. NEVER USE FINGERS TO FEED FOOD BY HAND. ALWAYS USE THE THE FOOD CARRIAGE! Always use the meat slicer completely assembled with food carriage and food pusher. Use protective cut-resistant gloves whenever handling the blade.

IMPORTANT

Before using your Slicer for the first time, wash all parts thoroughly, taking particular care to remove all grease and oil from surface. Dry all parts thoroughly before reassembling. (REFER TO CLEANING & MAINTENANCE SECTION OF MANUAL)

5. OPERATING YOUR MEAT SLICER

Now that your Slicer is fully assembled and ready to use, it is time to slice your favorite meats, cheeses and vegetables. Be sure to read and fully understand the General Safety Rules at the beginning of this manual before you start.

1. Place the Meat Slicer on a flat stable surface.

Plug the appliance into a properly rated electrical outlet (120V AC, 60HZ).

NOTE: Be sure to remove protective blade guards from the edge of the Blade #8 before plugging slicer into outlet. These are used for shipping only.

2. Place food on to the Sliding Food Carriage #5 between the Adjustment Plate #3 and the Food Pusher #12. To avoid injury, ALWAYS use the Food Pusher Handle #11. (Fig. 02)

3. Turn the Thickness Adjustment Knob #2 to set the Adjustment Plate #3 for the desired cutting thickness. Turn clockwise for thinner cuts, counter-clockwise for thicker slicing. (Fig. 02)

FIGURE 02

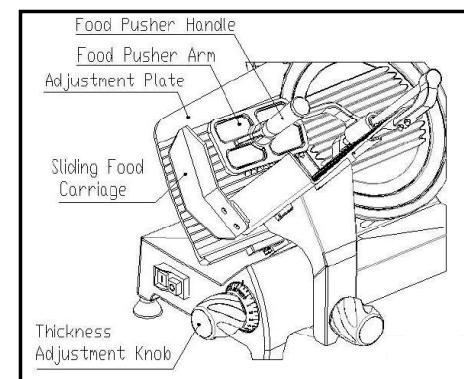

4. To turn the meat slicer ON, push the Green "I" button. (Fig. 03)
5. To turn the meat slicer OFF, push the Red "O" button.
6. When operating slicer, stand to the side of the slicer opposite the blade.
7. Place a tray or plate behind the Meat Slicer and below the Blade #8 to collect the sliced food as it exits the blade area.
8. Hold the Food Pusher Handle #11 with right hand. Keep your hands protected behind the Food Pusher #5.
9. **NEVER USE THIS SLICER WITHOUT THE FOOD PUSHER #12**
Important: Refer to "Food Slicing Tips" section, when slicing different types of food items.
10. Using an even, steady motion, SLOWLY begin slicing. Apply light steady pressure with the Food Pusher #12 to move food toward the Adjustment Plate #3 while SLOWLY sliding Food Carriage #5 over Blade #8; This will help assure even slicing. Continue sliding SLOWLY, back and forth, until you have sliced the desired amount of meat.
NOTE: Meat slicer only makes slices during the forward motion.
11. When finished, turn the meat slicer "OFF" (O) by pushing the Red button. (Fig. 03)
12. Always unplug meat slicer from power source when the Meat Slicer is not in use.
13. For safety, always rotate the Thickness Adjustment Knob #2 all the way to the "O" position after use to properly shield the sharp edge of Blade #8.

FIGURE 03

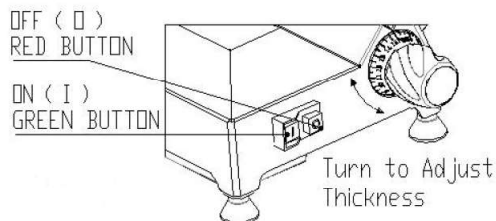

5.1 Food Slicing Tips

WARNING

This Meat Slicer is not meant to cut through any bones! Severe damage to Meat Slicer will occur and Warranty will be voided!

- Always debone meat before slicing
- Fruits should be free of seeds (peaches, apples, avocados etc.) The exception is tomatoes.
- **DO NOT** slice fully frozen foods.
- If you have to large of a cut of meat (roast or slab bacon) you may need to cut into a more manageable slicing pieces.
- Food with an uneven texture, like fish and thin steaks, are often difficult to slice. Put in freezer for approx. 20 minutes to partially freeze.

7. GENERAL SAFETY PRACTICES

IMPORTANT

If any recommendation is not applicable to your equipment, please ignore it .

The following safety instructions are addressed to both the operator of the machine as well as the person in charge of maintenance.

The machine has to be delivered only in perfect conditions of use by the Distributor to the user. The user shall operate the machine only after being well acquainted with the safety procedures described in the present manual. **READ THIS MANUAL WITH ATTENTION.**

IMPORTANT

Any change in the protection systems and safety devices will during operation, create serious risks to the operator physical integrity

7.1 Basic Operation Procedures

7.1.1 Dangers

Some areas of the electric device have parts that are connected or have parts connected to high voltage. These parts when touched may cause severe electrical shocks or even be lethal.

Never touch manual commands such as switches, buttons, turning keys and knobs with your hands wearing wet clothes and/or wet shoes. By not following these instructions operator could be exposed to severe electrical shocks or even to a lethal situation.

4.1.2 Warnings

- * The operator has to be well familiar with the position of ON/OFF Switch to make sure the Switch is easy to be reached when necessary.
- * Before any kind of maintenance, physically remove plug from the socket.
- * Provide space for a comfortable operation thus avoiding accidents.
- * Water or oil spilled on the floor will turn it slippery and dangerous. Make sure the floor is clean and dry.
- * Before using any commands (switch, buttons, lever), be sure it is the correct one. In case of doubt, consult this manual.
- * Never touch any manual commands (switch, buttons, lever) unadvisedly.
- * If any work is to be made by two or more persons, coordination signs will have to be

6.2 Storage

Make sure Blade #8 is securely tightened and locked.

1. Rotate the Thickness Adjustment Knob #2 all the way to the "O" position.
2. ALWAYS Align Adjustment Plate #3 with Blade #8 to protect the Blade #8 when the slicer is stored.
3. A storage cover is provided, cover and store in a dry, warm, low humidity area.

FIGURE 06

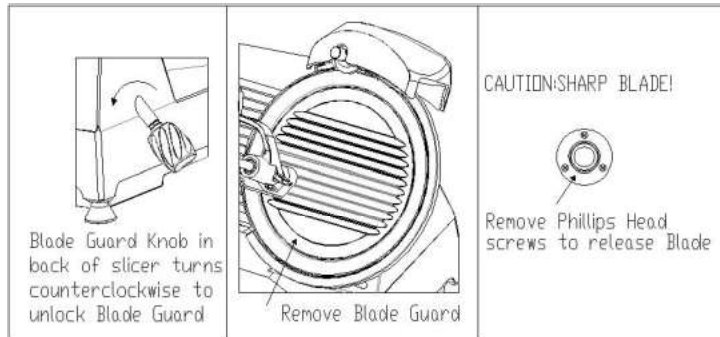

6.3 Adjusting the Sliding Food Carriage

1. The carriage should slide freely along carriage rod when slicing.
2. Should these parts not slide smoothly, adjustments can be made.
3. At the bottom of the carriage support, you will find a plastic screw. Turn the screw clockwise to tighten carriage

- (A) This will help to stabilize carriage. Turn the screw counterclockwise to loosen carriage
(B) This will help carriage slide more easily.

FIGURE 07

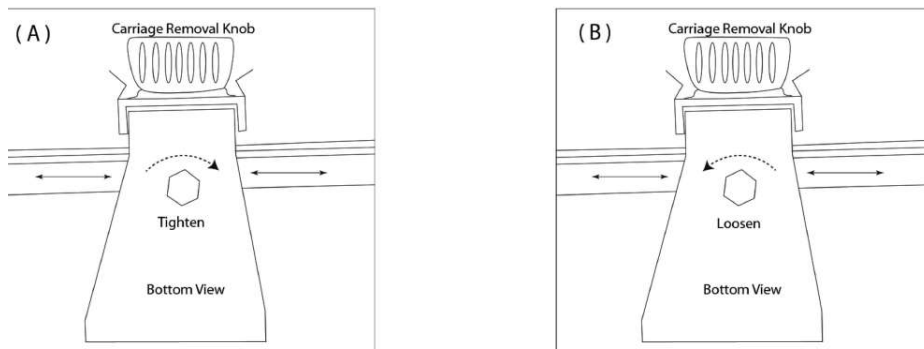

Cold cuts: Cold cuts keep longer and retain flavor if sliced as needed. For best results, chill to approx.:40°- 48°. Remove any plastic or hard casings before slicing. Use a constant, gentle pressure for even slicing. See "IMPORTANT" for best slicing results.

Cheese: Cheese can be difficult to slice (especially soft cheeses). A tiny amount of Mineral Oil can be lightly applied to blade with a paper towel, to keep the cheese from sticking during slicing. Caution -Blade sharp. Chill cheese thoroughly to approx. 40° - 48° before slicing. Before serving, allow cheese to reach room temperature.

IMPORTANT: If cheese is (sticking to) binding on the blade when slicing:

- A) Re-chill cheese so it is colder (not frozen).
- B) Use less tension on the Food Pusher #12 against the blade.
- C) Use SLOWER slicing strokes.

Breads & Cakes: Freshly baked bread should be cooled to room temperature before serving. Use day old bread for extra thin slices for toast. Your slicer is ideal for all types of breads, pound cake or fruit cake. Chill breads or cakes to approx. 40° - 48° for easier slicing and to avoid tearing or crumbling.

Hot Roasts: Beef, Pork, Lamb, Turkey, Ham: When slicing warm boneless roasts, remove from oven and let it set for 20-30 minutes (room temp) before slicing. They will retain more natural juices and slice evenly without crumbling. Cut the roast if necessary, to fit on the feeder. If roast is tied, turn off motor and remove strings one at a time as strings near blade.

5.2 Blade Sharpening Tips

WARNING

**Note: Always clean the edge of the blade before sharpening.
Always wear protective eye wear when sharpening the blade!**

If the meat slicer begins to produce uneven or broken slices, it may be blunt and require sharpening.

To sharpen the blade:

1. Unscrew the Sharpener release bolt and lift off the blade sharpener.
2. Rotate the sharpener 180° and insert it back into the appliance.
3. Tighten the Sharpener release bolt to secure the sharpener.
4. Start the appliance.
5. Press and hold down the rear sharpening stone button to sharpen the blade. Do not exceed one minute of constant sharpening.

6. Release the rear stone and press down the front sharpening Stone button for a few seconds to smooth the edge of the blade.

7. Turn off the appliance and return the sharpener to its original position, ensuring it is securely tightened.

FIGURE 04

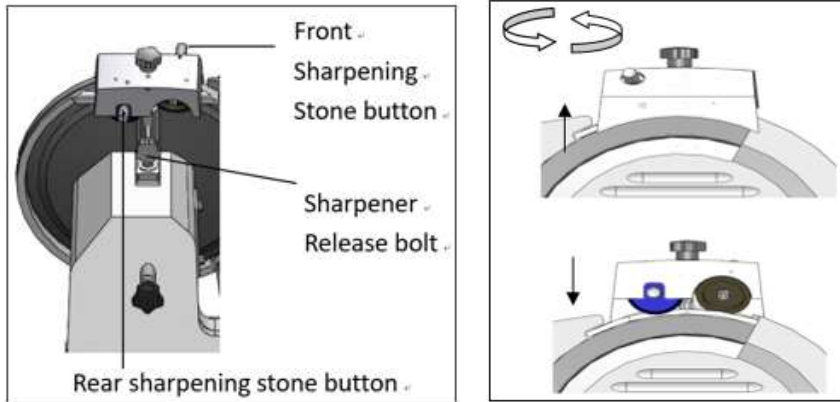

6. CLEANING YOUR MEAT SLICER

WARNING

Before cleaning, assembling or disassembling the MEAT SLICER, make sure POWER is OFF & PLUG IS REMOVED from the outlet/power source!

WARNING

BLADE SHARP! Handle Carefully!

6.1 To Disassemble Slicer

1. The slicer should be cleaned after every use as perishable food scraps could accumulate on the slicer or behind cutting Blade #8.
2. Do not use steel wool or abrasives to clean any part of Meat Slicer.
3. Rotate the Thickness Adjustment Knob #2 all the way to the "0" position.
4. To remove the Sliding Food Carriage #5 and Food Pusher Arm #12 unscrew the Carriage Knob #4 underneath the Sliding Food Carriage #5 counterclockwise and lift the food tray in an slight upward and out motion. (Fig. 05)

FIGURE 05

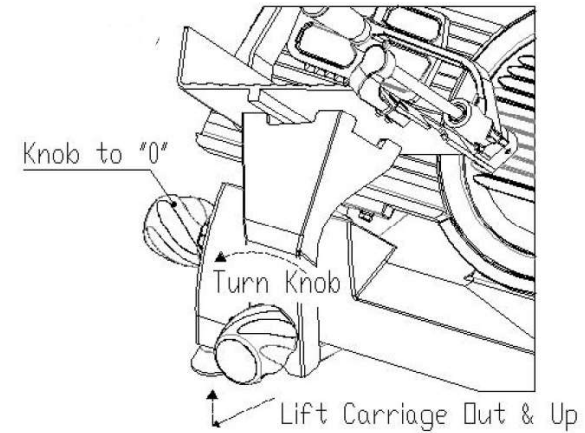

5. With one hand flat on Blade Guard #9 turn the black Blade Guard Knob #14 (located, on the back of the slicer, behind blade) counterclockwise until the Blade Guard #9 is released. (Fig. 06)

6. Remove the three Phillips head screws that hold Blade #8. (Fig. 06) IMPORTANT: Use Extreme Caution when handling or cleaning the Blade #8, as it is extremely sharp! It is highly recommended

to wear cut-resistant gloves when removing, cleaning and re-installing the blade.

7. The Blade #8 is now released from shaft and can be removed by gently pulling outward.

8. Clean the blade with a moist sponge or cloth. Wipe away from the Blade #8.

9. NEVER wipe toward the Blade.

10. NEVER clean Blade #8 underwater, handling sharp objects under water is Extremely Dangerous.

11. The Blade #8, Blade Guard #9, Food Pusher #12 and Food Carriage #5 all can be hand washed in hot soapy water. Because these parts come in contact with food, they should be sanitized properly. Allow sanitized parts to air dry.

12. Never immerse the Motor Assembly of the Meat Slicer in water or other liquid.

13. Clean the outer surface of the Meat Slicer Body/Motor with a damp cloth and mild detergent.

DO NOT WASH ANY PART OF THIS SLICER IN A DISHWASHER

To Re-assemble: USE EXTREME CAUTION! BLADE SHARP! Handle Carefully!

1. Be sure the Thickness Adjustment Knob #2 is all the way to the "0" position.
2. Screw the Blade #8 back into place.
3. Line up Blade Guard #9 over the blade hole. Hold in place so the lines of the Blade Guard #9 face, match the lines of Adjustment Plate #3 (horizontal). While holding Blade Guard #9 in place, turn the Blade Guard Knob #14 clockwise until the Blade Guard #9 screws into place. As the Blade Guard Knob #14 is tightens the Blade Guard #9 will become nearly flush with blade.